

FIRE DEPARTMENT LADDERS

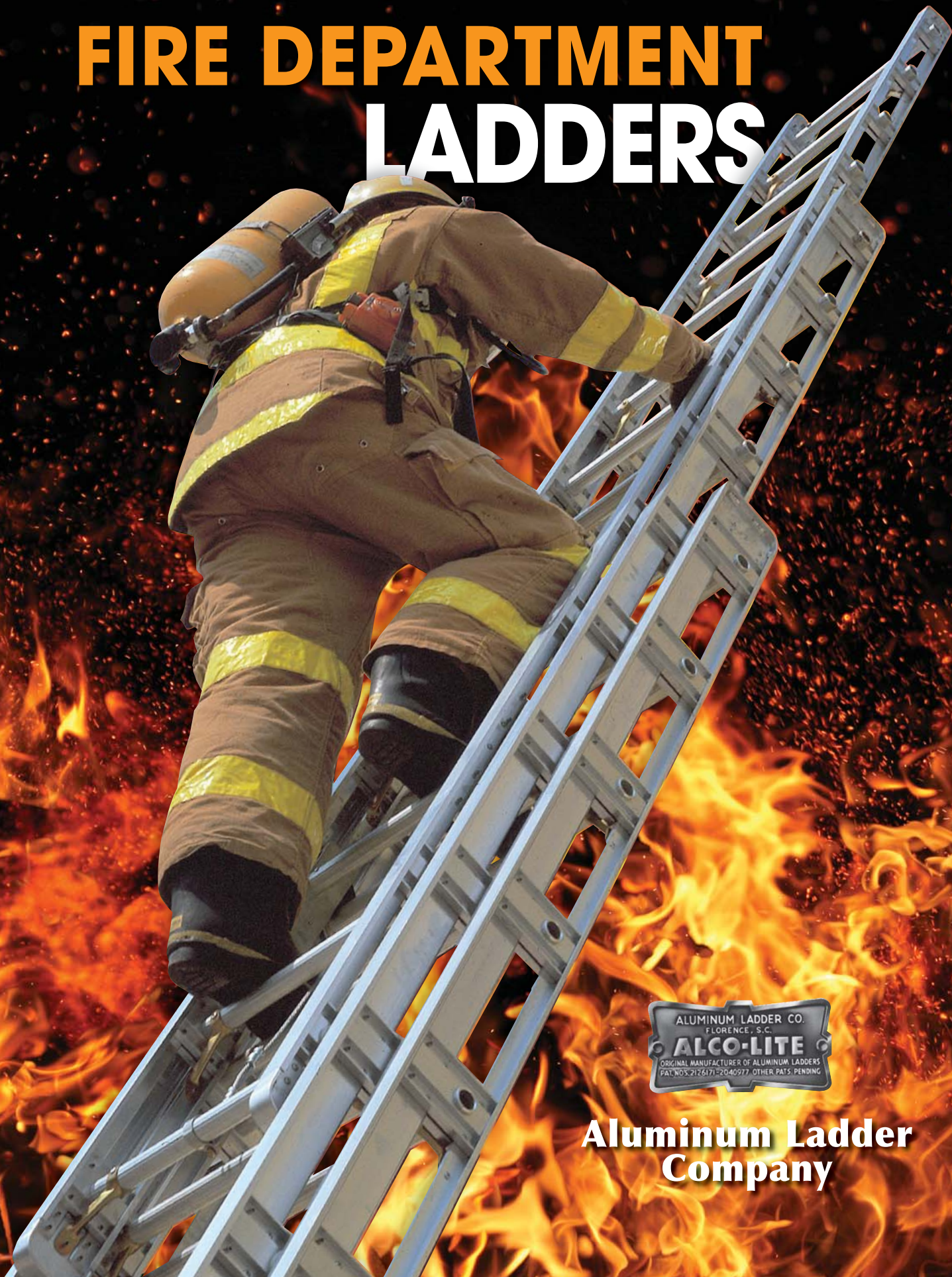

**Aluminum Ladder
Company**

CUSTOMER SERVICE



Superior Quality, Superior Customer Service
Experience the Difference

Our customer service representatives are trained in good customer service and what it is (and isn't).

We are here for you

- Your phone call will be answered
- We will keep promises made to you
- We listen to you
- Any complaints will be handled
- Our representative will always be helpful, courteous, and knowledgeable
- We take the extra step

Customer service is an integral part of our job and is never seen as just an extension of it. Our most vital asset is our customers. Without you, we would not, and could not, exist in business. We understand that when we satisfy you, you not only help us grow by continuing to do business with us, but you also recommend us to friends and associates.



Karen Miller Mellette
Fire Department Manager

I have been with the Cramer Family Businesses for over twenty (20) years. I have held many positions through the years, helping all of our clients succeed. Providing great customer service has always been my top priority and concern. If I can't do my job correctly, then you can't do yours.

The opportunity to work in the fire industry came as a welcomed surprise as I have been treated like family. You have all taken me under your wings and provided guidance; and, for that, I am truly blessed.

Our pride comes from treating every client as if they are family. We are the company that calls you back and takes care of you. We know the importance of our providing you with the best customer service available to help meet your needs. We strive to meet those needs on a daily basis as the fire industry is always there when we call on you.

We are proud to be a part of the "Fire Industry Family", and we will take care of you like family. I hope your experience with Aluminum Ladder Company will be as "fabulous" as mine has been.

SURE-STEP II Access Ladder

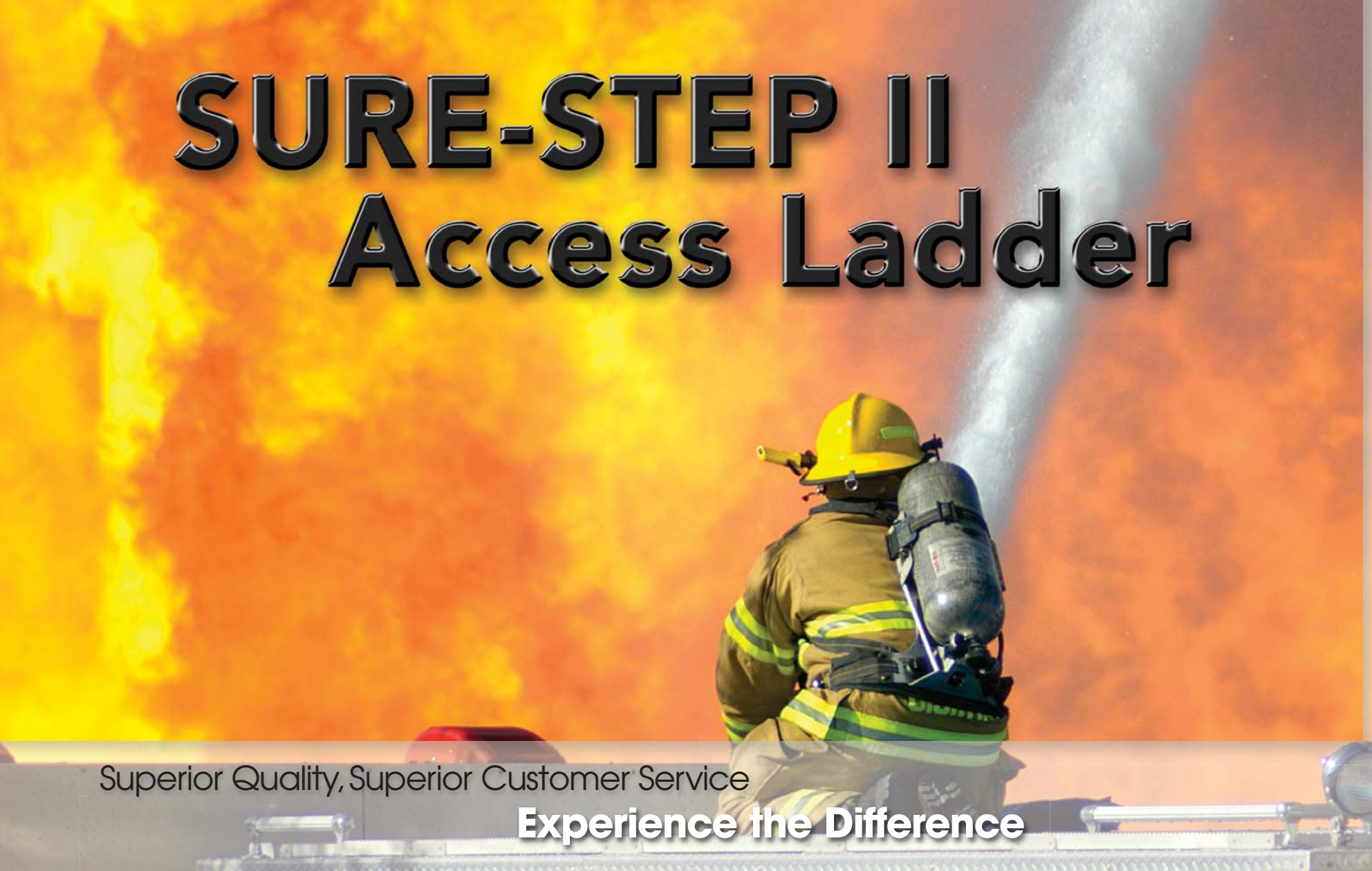

Superior Quality, Superior Customer Service
Experience the Difference

SURE-STEP II is a durable, operator-friendly ladder that provides safe access to the top of any apparatus. The ladder stores in a low profile position parallel to the truck body. To use, the bottom section simply flips down, rotating the ladder to a comfortable ten degree climbing angle. When finished, the bottom section flips up causing the ladder to return to a vertical stored position. The cam-action design locks the ladder in both the working and stored position, providing a simple one hand operation.

How it Operates

- Pull out and down on the lower flip up section to rotate ladder from stored to a safe 10 degree working position.
- The cam-action design locks the ladder in both the working and stored position for easy, one-step operation.

Sure-Step II is now safe for operation. Climb with confidence and feel the difference.

- When finished swing the step up as the ladder retracts to a vertical stored position.
- The cam-action design allows the ladder to remain vertical without vibration or rattles.

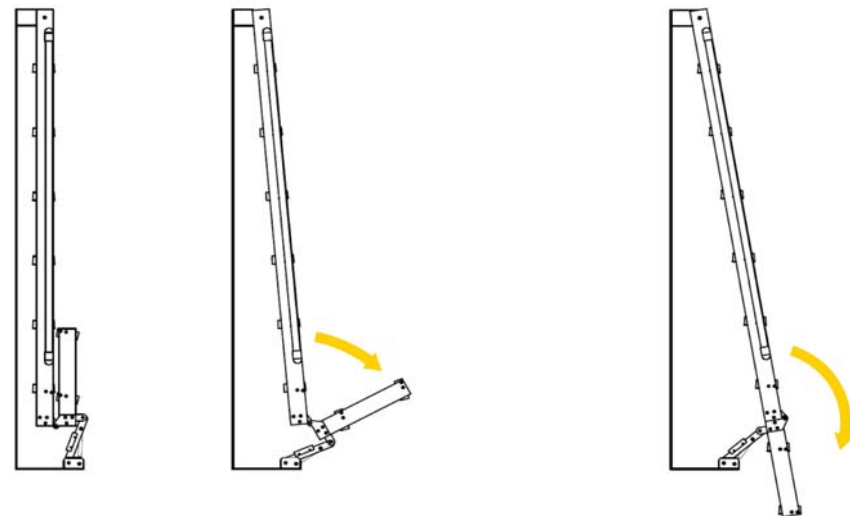

Built
Fire Fighter
Tough



- 1 Heavy-duty stainless steel stanchions
- 2 Stainless steel hardware
- 3 Heavy-duty mounting brackets
- 4 Cast aluminum, slip resistant tread
- 5 Non-slip handrail
- 6 Cam-action pivoting design
- 7 Heavy-duty gas struts
- 8 Durable aluminum construction

TRUSS LADDERS



Superior Quality, Superior Customer Service
Experience the Difference

ALCO-LITE® truss construction ladders have been a tradition in the industry since their inception by our founder. Built with the same work ethic and craftsmanship as those of the 1930's, you can depend upon their truly traditional quality.

Features

- Field repairable with factory parts
- All TEL and TEL3 extension ladders equipped with 1/2" diameter halyards
- TRL nests in base section of TEL or TEL3 models
- Truss design for maximum strength to weight ratio
- Meets/exceeds N.F.P.A. 1931 standards
- Strong - rugged
- Special width for replacement ladders available upon request
- Oversized 2-1/4" pulley for easy operation

Benefits

- All of our replacement parts are in stock and available for immediate shipment — helping to minimize out-of-service time.
- Rungs are replaceable at your location — 2 people can replace a rung within 15 minutes. Only Alco-Lite® fire ladder rungs can be quickly and simply removed at your location without the need for special tools, welding, or training.

TRL Series

Aluminum Truss Type Roof Ladder

Model	Length	Width	Banking Thickness	Weight
TRL-12	12' 5"	19-1/16"	3-3/4"	43 lbs
TRL-14	14' 9"	19-1/16"	3-3/4"	50 lbs
TRL-16	16' 11"	19-1/16"	3-3/4"	56 lbs
TRL-18	18' 2"	19-1/16"	3-3/4"	60 lbs
TRL-20	20' 6"	19-1/16"	3-3/4"	65 lbs
TRL-24	24' 0"	19-1/16"	3-3/4"	76 lbs
TRL-26	26' 4"	19-1/16"	5-7/16"	92 lbs
TRL-28	28' 8"	19-1/16"	5-7/16"	100 lbs

TEL Series

Aluminum Two-Section Truss Type Ladder

Model	Extended Length	Closed Length	Width	Banking Thickness	Weight
TEL-20	20'	13' 0"	22-1/4"	6-7/16"	93 lbs
TEL-24	24'	15' 4"	22-1/4"	6-7/16"	110 lbs
TEL-28	28'	16' 6"	22-1/4"	6-7/16"	118 lbs
TEL-30	30'	17' 8"	22-1/4"	6-7/16"	126 lbs
TEL-35	35'	20' 0"	22-1/4"	6-7/16"	141 lbs
TEL-40	40'	22' 4"	22-1/4"	6-7/16"	165 lbs
TEL-40P	40'	22' 4"	22-1/4"	8-1/8"	214 lbs
TEL-45P	45'	25' 10"	22-1/4"	8-1/8"	232 lbs
TEL-50P	50'	28' 2"	22-1/4"	8-1/8"	250 lbs

TEL3 Series

Aluminum Three-Section Truss Type Ladder

Model	Extended Length	Closed Length	Width	Banking Thickness	Weight
TEL3-24	24'	12'	25-3/8"	9-1/16"	142 lbs
TEL3-28	28'	13' 2"	25-3/8"	9-1/16"	154 lbs
TEL3-30	30'	14' 4"	25-3/8"	9-1/16"	163 lbs
TEL3-35	35'	15' 6"	25-3/8"	9-1/16"	175 lbs
TEL3-40	40'	16' 8"	25-3/8"	9-1/16"	190 lbs
TEL3-40P	40'	16' 8"	27"	9-1/16"	223 lbs
TEL3-45P	45'	19' 0"	27"	10-3/4"	242 lbs
TEL3-50P	50'	20' 2"	27"	10-3/4"	273 lbs

Nesting

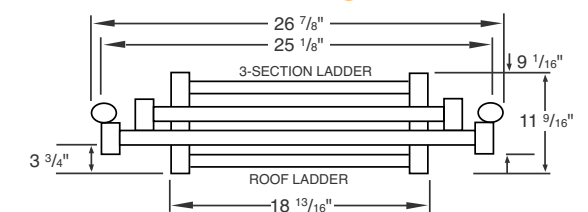

SPECIAL REQUIREMENTS
NOTE: ON TRUSS TYPE LADDERS, THE RUNGS PROJECT 1/4"
PAST SIDE RAIL DIMENSION AS SHOWN

PUMPER LADDERS



Superior Quality, Superior Customer Service
Experience the Difference

ALCO-LITE® pumper ladders have been the standard in the industry since 1930 — engineered and manufactured to exacting standards for use on general fire fighting trucks and pumper trucks.

Features

- Field repairable with factory parts
- Special widths for replacement ladders available upon request
- All PEL and PEL3 extension ladders equipped with 1/2" diameter halyards
- Roof ladder equipped with reinforcing brace between hooks for increased rigidity
- Meets/exceeds N.F.P.A. 1931 standards
- Equipped with high strength steel butt spurs and rounded aluminum end caps for increased durability; oversized 2-1/4" pulley for easy operation

Benefits

- All of our replacement parts are in stock and available for immediate shipment — helping to minimize out-of-service time.
- Rungs are replaceable at your location — 2 people can replace a rung within 15 minutes. Only Alco-Lite® fire ladder rungs can be quickly and simply removed at your location without the need for special tools, welding, or training.

Also
available in
Fiberglass

PRL Series Aluminum Pumper Type Roof Ladder

Model	Length	Width	Banking Thickness	Weight
PRL-08	8' 5"	18-1/2"	2-7/8"	27 lbs
PRL-10	10' 9"	18-1/2"	2-7/8"	33 lbs
PRL-12	12' 0"	18-1/2"	2-7/8"	36 lbs
PRL-14	14' 3"	18-1/2"	2-7/8"	42 lbs
PRL-16	16' 7"	18-1/2"	2-7/8"	48 lbs
PRL-18	18' 10"	18-1/2"	2-7/8"	54 lbs
PRL-20	20' 0"	18-1/2"	2-7/8"	60 lbs

PEL Series Aluminum Two-Section Pumper Type Ladder

Model	Extended Length	Closed Length	Width	Banking Thickness	Weight
PEL-12	12'	8' 5"	21"	5-1/16"	48 lbs
PEL-14	14'	9' 7"	21"	5-1/16"	53 lbs
PEL-16	16'	10' 9"	21"	5-1/16"	59 lbs
PEL-20	20'	12' 0"	21"	5-1/16"	66 lbs
PEL-24	24'	14' 3"	21"	5-1/16"	75 lbs
PEL-28	28'	16' 7"	22"	5-13/16"	114 lbs
PEL-30	30'	17' 9"	22"	5-13/16"	122 lbs
PEL-35	35'	20' 1"	22"	5-13/16"	139 lbs

PEL3 Series Aluminum Three-Section Pumper Type Ladder

Model	Extended Length	Closed Length	Width	Banking Thickness	Weight
PEL3-24	24'	12' 2"	23-1/2"	7-1/4"	105 lbs
PEL3-28	28'	13' 4"	25"	8-1/4"	145 lbs
PEL3-30	30'	14' 6"	25"	8-1/4"	158 lbs
PEL3-35	35'	15' 8"	25"	8-1/4"	170 lbs
PEL3-40	40'	17' 0"	25"	8-1/4"	200 lbs
PEL3-40P	40'	17' 0"	26"	8-1/4"	220 lbs

Nesting

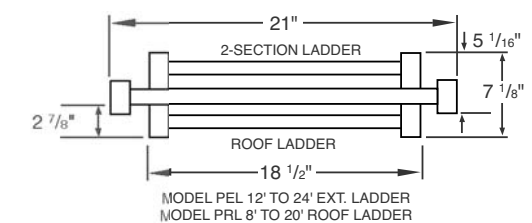

COMPACT PUMPER LADDERS

Superior Quality, Superior Customer Service
Experience the Difference

ALCO-LITE® pumper ladders have been the standard in the industry since 1930 -- engineered and manufactured to exacting standards for use on general fire fighting trucks and pumper trucks.

Features

- Field repairable with factory parts
- Special widths for replacement ladders available upon request
- Equipped with 1/2" diameter halyards
- Meets/exceeds N.F.P.A. 1931 standards
- Equipped with high strength steel butt spurs and rounded aluminum end caps for increased durability; oversized 2-1/4" pulley for easy operation

Benefits

- All of our replacement parts are in stock and available for immediate shipment — helping to minimize out-of-service time.
- Rungs are replaceable at your location — 2 people can replace a rung within 15 minutes. Only Alco-Lite® fire ladder rungs can be quickly and simply removed at your location without the need for special tools, welding, or training.

PEL3 Series Compact Pumper Type Ladder Three Section

Model	Extended Length	Closed Length	Width	Banking Thickness	Weight
PEL3-16	16'	7' 4-1/2"	23-1/2"	7-1/4"	61 lbs
PEL3-19	19'	8' 6-1/2"	23-1/2"	7-1/4"	70 lbs



COMBINATION LADDERS



Superior Quality, Superior Customer Service
Experience the Difference

ALCO-LITE® combination ladders are functionally engineered for ease of operation as a step or extension ladder. Ideal for spanning fences, accessing windows, or as a self-supporting ladder set up in the center of a room.

Features

- Converts easily to extension ladder or "A" ladder
- Ideal for spanning a fence, working on a light ballast, or in the center of a room
- Accessible from both sides
- Special heavy-duty "A" bracket allows for quick, easy set-up
- Compact design is easy to maneuver in tight hallways and stairwells
- Meets/exceeds N.F.P.A. 1931 standards
- Field repairable with factory parts

Benefits

- All of our replacement parts are in stock and available for immediate shipment — helping to minimize out-of-service time.
- Rungs are replaceable at your location — 2 people can replace a rung within 15 minutes. Only Alco-Lite® fire ladder rungs can be quickly and simply removed at your location without the need for special tools, welding, or training.

CJL Series

Combination Ladder

Model	Closed Length	Height in "A" Position	Width in "A" Position	Width	Banking Thickness	Weight
CJL-10	6' 2"	5' 10"	4' 3"	20-1/2"	6-3/8"	27 lbs
CJL-12	7' 4"	7' 0"	4' 11"	20-1/2"	6-3/8"	29 lbs
CJL-14	8' 6"	8' 2"	5' 4"	20-1/2"	6-3/8"	33 lbs
CJL-16	9' 8"	9' 1"	6' 5"	20-1/2"	6-3/8"	38 lbs



FOLDING LADDERS



Superior Quality, Superior Customer Service
Experience the Difference

ALCO-LITE® folding ladders offer the ultimate in portability for low to medium height access. Compact design easily fits on any service vehicle.

Features

- Hinge locks ladder into open position
- Lightweight for easy carrying
- Folds laterally into 5-1/4" wide compact unit for easy storage and transportation
- Equipped with handles for safe, easy maneuvering and set-up
- Meets/exceeds all N.F.P.A. 1931 standards
- Designed for maximum one-man load
- Available with slip-resistant fixed rubber cap feet

Benefits

- All of our replacement parts are in stock and available for immediate shipment — helping to minimize out-of-service time.
- Rungs are replaceable at your location — 2 people can replace a rung within 15 minutes. Only Alco-Lite® fire ladder rungs can be quickly and simply removed at your location without the need for special tools, welding, or training.

FL Series Folding Ladder

Model	Open Length	Folded Length	Folded Width	Open Width	Banking Thickness	Weight
FL-08	8' 3"	9' 3"	5-1/4"	15-1/2"	2"	12 lbs
FL-10	10' 6"	11' 5"	5-1/4"	15-1/2"	2"	14 lbs
FL-12	12' 8"	13' 8"	5-1/4"	15-1/2"	2"	17 lbs
FL-14	14' 11"	15' 11"	5-1/4"	15-1/2"	2"	21 lbs



ATTIC LADDERS

Superior Quality, Superior Customer Service
Experience the Difference

ALCO-LITE® "Fresno" style attic ladders are ideal for use in accessing small attic openings or other medium height close quarter areas.

Features

- Optional heavy-duty swivel safety shoes available
- Meets/exceeds N.F.P.A. 1931 standards
- Field repairable with factory parts

Benefits

- All of our replacement parts are in stock and available for immediate shipment — helping to minimize out-of-service time.
- Rungs are replaceable at your location — 2 people can replace a rung within 15 minutes.
Only Alco-Lite® fire ladder rungs can be quickly and simply removed at your location without the need for special tools, welding, or training.

AEL Series Attic Extension Ladder

Model	Extended Length	Closed Length	Width	Banking Thickness	Weight
AEL-10	10'	7' 3"	13-1/2"	5-1/16"	41 lbs
AEL-12	12'	8' 5"	13-1/2"	5-1/16"	46 lbs
AEL-14	14'	9' 7"	13-1/2"	5-1/16"	51 lbs



BOOM LADDERS

Superior Quality, Superior Customer Service
Experience the Difference

ALCO-LITE® engineered telescoping boom ladders have been the standard ladder of choice for many fire apparatus manufacturers for decades. These ladders are manufactured to exact standards to ensure proper integration with all kinds of equipment. We will be happy to produce custom ladders to your specifications or have our engineers design one for you. Either way, you will be assured of getting ALCO-LITE® quality that's delivered on time.

Features

- Booms up to 5 sections, 100'
- Fixed or fold down handrails
- Meets/exceeds N.F.P.A. 1931 standards
- Field repairable with factory parts

Benefits

- All of our replacement parts are in stock and available for immediate shipment — helping to minimize out-of-service time.
- Rungs are replaceable at your location — 2 people can replace a rung within 15 minutes. Only Alco-Lite® fire ladder rungs can be quickly and simply removed at your location without the need for special tools, welding, or training.

LADDER USAGE



Superior Quality, Superior Customer Service
Experience the Difference

Even the sturdiest, best-engineered piece of equipment must be properly used for maximum safety. The following recommendations will help you obtain maximum service and safety from your ALCO-LITE® fire department ground ladders. These are only a few of the items you need to be aware of in using, inspecting, and testing your ALCO-LITE® fire department ground ladders. For additional information on proper usage, inspection, and testing, please refer to the current N.F.P.A. 1932 standard and the I.F.S.T.A. fire department ground ladder standard. Those practices permitted in **BOTH** standards are recommended, and their safety procedures must be obeyed.

One of the most vital areas of ladder safety is the correct placement angle of your ladder. This illustration shows the exact method for proper placement of ladders of varying lengths. With this method, the ladder is placed against the vertical plane (wall, etc.) at a 75-1/2° angle.

A simple formula for correct placement is to position the bottom of the ladder at a distance from the vertical plane equal to 1/4 the total working length of the ladder. At this angle, your ladder will give the best service and maximum strength.

$$\text{Correct placement (distance from wall, etc)} = \frac{\text{total working length of ladder}}{4}$$

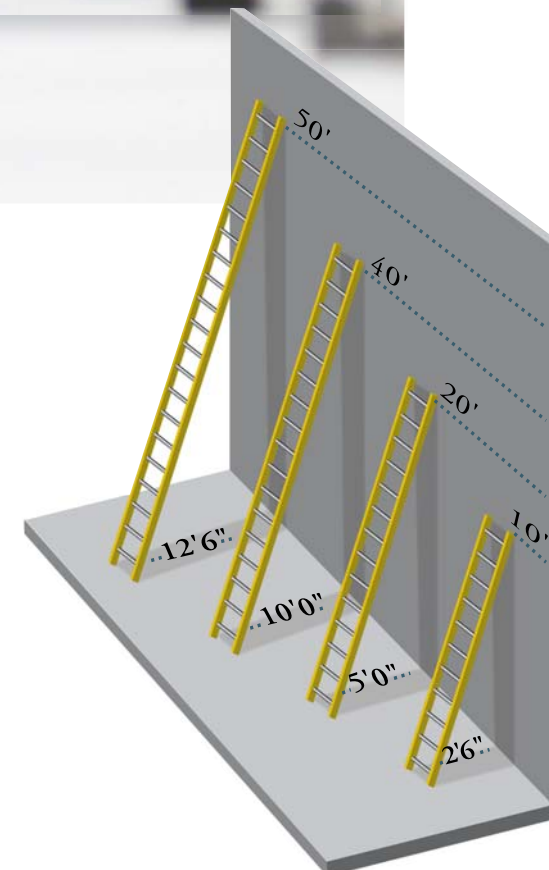

Diagram B

1. Inspect and test all ladders prior to placing in service.
2. Perform a visual inspection before and after every ladder usage.
3. All fire department ground ladders must be service tested in accordance with N.F.P.A. 1932 at least annually or any time the ladder integrity is suspected.
4. When carried on a truck, ladders must be fastened down with all contact points on mounting brackets padded to minimize abrasion.
5. Never store a ladder where it can be exposed to engine exhaust and heat.
6. Ladder shall be secured at the base, either by a fire fighter or mechanical means, to prevent slipping or displacement.
7. Ladder must be tied off at the top (whenever possible) to prevent slipping or displacement.
8. Always tie off the halyard to the base section prior to climbing.
9. Never overload a ladder. Refer to N.F.P.A. 1932 and the I.F.S.T.A. standards for proper ladder loading. If a ladder is ever positioned at a reduced angle (further out than 1/4 the effective length), the load-carrying capacity is significantly reduced.
10. Always position the ladder at the proper 75-1/2° angle (Diagram B). A ladder is safer and stronger when it is set at the proper 75-1/2° angle. This is approximately 1/4 of the distance to a support point out from the wall. See illustration in bottom right (Diagram B).



Diagram A

All ALCO-LITE® fire ladders now include a label on the side rail to help you properly position the ladder. (See example at left.) This label illustrates and instructs the proper way to position the ladder before climbing. When the illustrations are followed, the ladder will be set at the correct climbing angle of 75-1/2°.

RUNG REPLACEMENT



Superior Quality, Superior Customer Service
Experience the Difference

CAUTION!

Do not replace rung if side rail has been damaged. Contact ALCO-LITE for repair options.

Required Materials

- Wood 2 X 4 wider than the inside width of the ladder
- Replacement rung, bushings, and spanners
- Hacksaw
- Two wrenches large enough to fit 3/4" nuts
- Hammer
- 3/4" threaded rod X 3'-0" long
- Two 3/4" hex nuts (Grade 8)
- Two 3/4" flat washers
- Motor oil (to be used as a lubricant)
- Saw for cutting rung
- Flat bladed screwdriver

If there are any questions about the integrity of your ladder or the repair process, contact your ALCO-LITE® customer service representative immediately at:

1 • 800 • 752 • 2526

1. Lay ladder section with damaged rung on two sawhorses or other suitable support.
2. Clamp or secure ladder to support(s).
3. Cut out portion of damaged rung between ladder side rails. The cuts should be made about 1" from the side rails — see Illustration "a".
4. Insert hacksaw blade through rung section that is still inside - see Illustration "b".
5. Carefully saw through bushing. Use caution to not saw through the rung into the side rail. Place the screwdriver against the inside end of the bushing, and tap it out of the rung.
6. After removing the bushing, carefully saw almost through the rung, being careful to stop before cutting into the side rail. Tap the rung out of the side rail.
7. Repeat process on the other rung end.
8. Measure the length the 2 X 4 is to be cut — see Illustration "c". Cut 2 X 4 to this length.
9. To cut rung to required length, measure through a good rung on the ladder section and add 1/4". After cutting rung to required length, file inside of rung.
10. Put replacement rung through ladder side rails.
11. Squirt or brush oil in each end of the rung.
12. Assemble parts as shown in Illustration "c".
13. Make sure rung sticks out equally on each side of the ladder.
14. Push replacement bushings into the end of the rungs by hand.
15. Insert steel spanners into bushings until shoulder is against bushing.

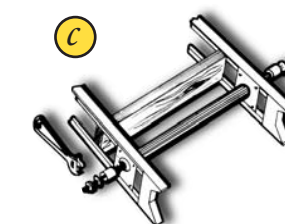
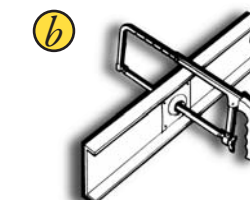
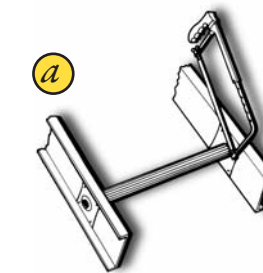

16. Hand tighten the nuts against the spanners.
17. Check to make sure the rung is still sticking out equally on each side.
18. Lubricate the bushings with oil. This must be done periodically throughout the tightening process.
19. Push the bushings into the rungs by tightening the nuts. Make sure the 2 X 4 is held in place and the rung sticks out equally on each side. Note: The bushings may not be pushed in at the same rate.
20. Continue tightening until both bushings are fully pushed in and flush with the end of the rung.
21. Loosen the nut and completely remove it from the threaded rod.
22. Pull threaded rod through the ladder and remove the spanner from inside the bushings.
23. Remove 2 X 4 and wipe off excess oil.

THINK SAFETY

Superior Quality, Superior Customer Service
Experience the Difference

Service Does Make A Difference

The best fire ladder is not any good unless it is on your truck, ready to be used. To maintain your fire ground ladders in the best condition, Aluminum Ladder Company will provide, upon request, detailed parts lists. This allows you to order the correct replacement parts and perform on-site repair and maintenance. Replacement ALCO-LITE® ladders are available to fit a ladder into a compartment in an older apparatus. Please contact our Customer Service Department, and

we will be happy to assist you in working out your nesting arrangements. Our staff is ready to service your fire ladder requirements. We'll work with you to develop a ladder plan to meet the needs of your fire department. When you need a fire ground ladder, call Aluminum Ladder Company, toll-free, and get the best equipment for your fire service needs.

Safety Note

Most ladder accidents happen during training exercises. This occurs for several reasons:

1. Many departments use older equipment in their training exercises. Remember, even older equipment must pass the current N.F.P.A. 1932 test loads in order to remain in service. Failure to test your ground ladders can result in ladder failure and fire fighter injury.
2. Many departments do not take all appropriate safety precautions in performing ladder drills; i.e., tying the ladder off at the top, tying the halyard to the base section of the ladder, bracing the foot of the ladder to prevent movement, or overloading the ladder. These items all cause unnecessary risk and injury potential for the fire fighters involved.
3. Never use a damaged ladder. Take it out of service until repaired and tested in accordance with N.F.P.A. 1932 standards.

Replacement Parts Made Easy

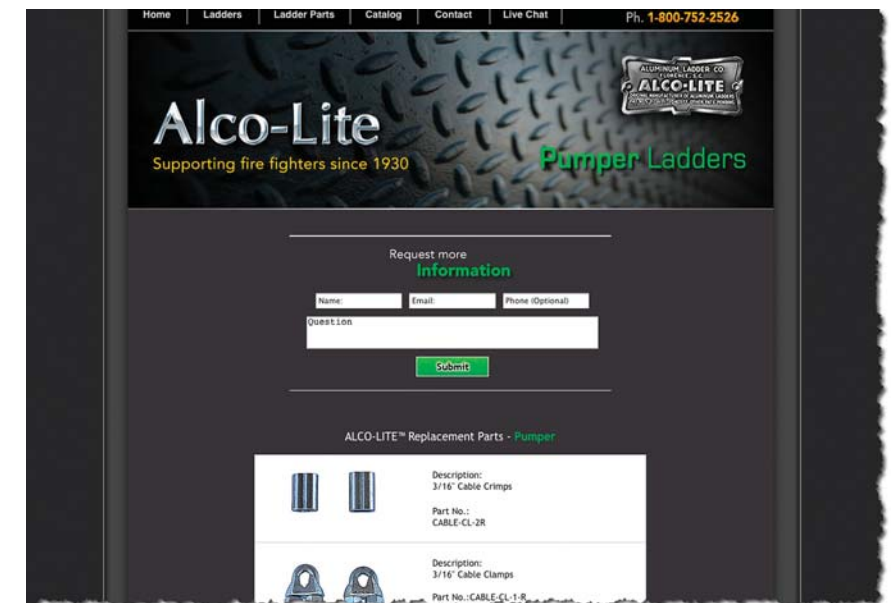

Need replacement parts? We have made ordering parts fast and easy. Go to www.FireLadder.com, and select **Ladder Parts** from the tabs. Select the ladder for which you need a replacement part, and you will see a complete list of parts with photographs.

THINK SAFETY



Superior Quality, Superior Customer Service
Experience the Difference

Inspection, Maintenance, and Testing

Fire ladders are part of your total apparatus inventory. Just as your engines, pumps, and other equipment require inspection, maintenance, and testing, so do your ladders. Begin by establishing a logbook for each ladder with its model number and serial number. Now you can record each inspection, maintenance performed, and annual test results.

Inspect and test ladders prior to placing in service. Always visually inspect a ladder before and after each use. Items of special concern are indications of

structural strain or damage on the side rails and/or rungs, loose rungs, worn or frayed halyards and cables, damaged pawls/locks, and heat sensor dots indicating high temperature exposure. Other areas needing attention include ease of extension with two and three-piece ladders, loose fasteners (nuts, rivets, etc.), damaged or missing end caps, foot spikes, and safety shoes (if equipped).

You must maintain, inspect, and test your ladders in accordance with N.F.P.A. 1932 standards.

Ladder maintenance can be separated into two procedures. The first, Repair Maintenance, should be performed any time the Visual Inspection discloses any defect. The Repair Maintenance procedure must be performed prior to using the ladder. Secondly, the preventive maintenance procedure reduces the likelihood of ladder damage and injuries. All ladders, regardless of the manufacturer or material of construction, require both procedures to ensure a safe ladder.

Repair Maintenance must be performed at any time the Visual Inspection discovers any problems as noted in the above section on visual inspection. Remove the ladder from service until such repairs can be completed! The manufacturer can supply you with the necessary parts. Should you have any questions concerning the condition of a ladder, please contact the manufacturer immediately for guidance.

General maintenance should begin by cleaning the ladder with soap and water, taking care to flush the inside of the rungs to remove debris, road salt, etc. (Aluminum ladders can be cleaned with a fine steel wool pad; fiberglass and wood ladders can be cleaned with a rag or sponge.) Use caution near the labels so as not to remove the outer label coating. Once the ladder is clean, perform a visual inspection to log any possible defects. After the defects are repaired, you can protect the ladder by applying a mild liquid car wax to the side rails. On extension ladders, apply paraffin wax or candle wax to the friction (slide) areas to lubricate the contact areas. Additionally, apply the wax to accessible lock parts. Under normal conditions, the inspection, washing, and waxing should be done twice a year. In a hostile environment, complete these steps more frequently as required.

Testing is the word that everyone loves to hate. You have a plan in force to test your personal protection gear and test your unit's brakes. Your life depends upon these items working properly when the need is greatest. Are ladders any different? **No, ladders are not different!** That's why the **National Fire Protection Association (N.F.P.A.)** requires that ground ladders be tested annually. They (N.F.P.A.) also require that you test ladders any time the ladders are damaged or exposed to high temperatures.

Again, at the time of this printing, the N.F.P.A. requires, as a minimum, that a ladder be tested annually. Become familiar with the current testing requirements and complete the tests. Give in; periodic testing of your ladders may save a life (perhaps your own)!



WARNING!

1. If dot on heat sensor label turns black, remove ladder from service and test to N.F.P.A. 1932 standards.
2. Check expiration date on all heat sensors and replace as required.

DO NOT APPLY HEAT SENSOR DOTS OR LABELS TO ANY LADDER THAT HAS NOT PASSED THE IN-SERVICE TESTING OF THE N.F.P.A. 1932 EDITION STANDARDS

Due to the expiration of Heat Sensor Labels, ALCO-LITE® cannot stock them. Labels can be ordered from Ladder Technologies - 1-800-207-9407 • www.laddertechnologies.com/hsl.htm

WHY BUY ALCO-LITE®

- Quality built ladders designed to provide decades of worry-free service.
- Damaged ladders have to be taken out of service immediately. You need quality replacement parts FAST! — Alco-Lite® carries replacement parts in-stock, ready to ship today.
- We understand the frustration of receiving faulty goods — ALL Alco-Lite® ladders go through a stringent quality control inspection to ensure your ladder is perfect before it leaves our facility.
- Rungs become damaged or broken — Alco-Lite® rungs are designed so you can easily replace them using common tools. Other manufacturers require you to weld the rung using specialty tools that have to be bought or rented.
- Our friendly, knowledgeable customer service representatives are here to help with your purchase and any after service needs.

**Built
Fire Fighter
Tough**



1.800.752.2526
www.FireLadder.com

