

## INTRODUCTION

PLEASE READ THIS GUIDE COMPLETELY BEFORE YOU BEGIN THE ERECTION OF YOUR BUILDING.

Follow the step-by-step instructions carefully and you will have an ALPINE building that will give you many, many years of service.

NOTE: The manufacturer of your ALPINE building may make certain changes in the design of the building or in the components during the model year, without notice. In cases of doubt, check with your dealer or contact the factory. The manufacturer cannot accept liability for errors which, despite careful checking, may occur in this guide.

CAUTION: Your insurance agent can provide you with construction insurance, before you start. Don't overlook this important step in building management: a sudden squall during construction can do serious damage!

NOTE: The factory ships 5% more bolts, nuts and caulking with your building than is actually needed. Experience shows that bolts or caulking are often lost at a construction site, due to careless handling. The manufacturer cannot assume responsibility for supplying additional bolts, nuts or caulking.

CAUTION: The bolts are plated with a special rust-resistant coating, which will protect them for the life of the building, under normal conditions. It is important not to damage this coating when tightening the bolts with an impact gun.

NOTE: This guide is a general illustration of standard erection procedures only. As we manufacture more than forty different models, your particular ALPINE building may differ from the illustrations in this manual.

CAUTION: BE CERTAIN TO WORK SAFELY and to take all necessary precautions to avoid accidents during construction. Do not ignore basic construction safety rules, such as wearing hard hats and boots on the site, and securing ladders and scaffolding against falling over. Wear safety gloves to protect your hands from the sharp edges of sheet metal components.

Again, it is important to read this guide completely. Verify foundation and building dimensions, and make certain that you fully understand all instructions before construction begins. If you have questions, you may want to phone the Engineering Department at the factory; the phone number is 1-800-668-5422. In that case, please note model number, door sizes, order number and all relevant dimensions before you make the call; this will help our technical staff considerably.

## TABLE OF CONTENTS

INTRODUCTION	1
TABLE OF CONTENTS	2
EQUIPMENT LIST	3
FOUNDATION DIMENSIONS	5
SITE PREPARATION	10
CONSTRUCTING THE FORMS	13
REINFORCING STEEL	14
PLACING THE CONCRETE	18
FINISHING THE FOUNDATION	20
ERECTING THE ARCHES	22
ERECTING THE FRONT WALL	46
SLIDING DOOR ASSEMBLY	62
ERECTING THE REAR WALL	71
GROUTING	73
INSTALLING VENTILATORS	76
INSTALLING SKYLIGHTS	80
INSTALLING SERVICE DOORS	82

## LIST OF MATERIALS AND EQUIPMENT

NOTE: The list of materials and equipment shown below includes the equipment we recommend for the average installation. Special conditions or non-standard buildings may require more or other equipment. Your ALPINE dealer may be able to give you advice, or to refer you to an experienced contractor.

NOTE: The materials listed are NOT supplied with the building. Most can be purchased at a hardware store. Some of the equipment can often be rented at reasonable rates.

### EQUIPMENT

- Hard hats and work gloves
- Tape measures, 50 or 100 ft. and 10 ft.
- Wheelbarrow (contractors' size) and shovels
- Trowels, wood float and spirit level
- Builders' wire for stringlines
- Handsaw, hacksaw, power (circular) saw and saber saw
- Hammers and nails
- Crowbar
- Electric drill, 3/8" minimum, variable speed
- Drill bits, 3/8", for sheet steel
- Electric impact wrench with 1/2" hex or 9/16" square sockets
- 1/2" and 9/16" wrenches
- Extension ladders and/or rope ladders
- Tapered drift pins and plumb bobs
- Scaffolding and stepladders, rope

### MATERIALS

- Lumber, 2"x 4" or 2"x 3" and 1"x 3"
- Plywood, 3/4" and 1/2"
- Steel reinforcing bars no. 3, 4 and 6 (10m, 15m, 20m)
- Steel tie wire, 16 gauge, black
- Welded steel wire mesh, 6"x 6" by no. 6/6 gauge
- Sand, granular fill, crushed stone
- Polyethylene sheeting, 6 mils
- Steel strapping and wire loops

NOTE: You may not need all equipment or material shown above. Much depends on the site and the type of foundation you want, as well as on price and availability. Throughout this manual, details of recommended materials will be given. Remember, however, that local conditions may require other specifications.

## NOTES ON FOUNDATION CONSTRUCTION

While this guide shows specific foundation details and dimensions it is illustrative only, as the soil and climatic conditions governing the design of the foundation for your ALPINE building could be totally different from those used in designing the prototype foundation described in this guide.

We recommend that you engage a professional civil engineer to design the foundation and to supervise construction to ensure that the design details are correctly interpreted. The engineer will require information on soil conditions at the site. He may rely on his own knowledge of conditions in the area, or else he may suggest an examination of the site by a soil specialist, to determine the engineering characteristics for foundation design.

Site selection and preparation are important. No two sites are exactly the same, and a professional engineer can offer valuable assistance in selecting the site, determining what site preparation is required and in interpreting local building by-laws. As these by-laws vary across the country the engineer can also check conformity of your ALPINE building with local regulations, and, where necessary, suggest modifications.

Remember that the successful performance of your finished ALPINE is largely dependent on having an adequate supporting foundation. Proper construction and reinforcement of your foundation is perhaps the most important step in the construction of your building. We strongly urge you to carefully study this guide, but we point out once again that the guide is illustrative only, and may not satisfy the conditions existing on your site.

The reinforcing steel shown in this guide is also for illustrative purposes only. Reinforcing steel should be detailed, formed and placed by people experienced in that kind of work, working to foundation drawings prepared or approved by a registered professional civil engineer.

**CAUTION: If you are going to erect your building on steel base connectors rather than in a concrete trough, this foundation guide does not apply, and you should ask your dealer for a special manual describing foundations for base connectors and base channels.**

## DETERMINING FOUNDATION DIMENSIONS

This guide describes two "standard" foundations:

"Package 1" has sliding doors at one end and a solid (blind) endwall at the other end. The end with the doors is always referred to as the front of your ALPINE building.

"Package 2" has sliding doors at both ends of the building.

NOTE: If your ALPINE building deviates from the standard packages, please consult your dealer. He can usually tell you if your foundation needs any changes, and if necessary he will contact the factory and request a special foundation diagram.

Determining the main dimensions of your foundation is quite a simple matter, if you follow the steps outlined below:

1. Look at your copy of the sales order and establish the model number, the number of arches and the package number of the building you ordered.
2. Next, find the model number in table 1 on the next page and note the dimension given for that model. This dimension is the overall width of your foundation (Dimension W).
3. Now find the number of arches in table 2 on page 7 and again note the dimension shown. This is the overall length of your foundation (Dimension L).
4. If the package number is 1, you will find a schematic diagram of your foundation on page 8. For a diagram of a package 2, see page 9.

TABLE 1

MODEL	WIDTH
A20-12	21'-9"
A25-12	26'-8"
A25-14	26'-9"
A30-14	31'-8"
A30-16	31'-9"
A32-18	32'-11"
A35-14	36'-10"
A35-16	36'-11"
A40-16	41'-10"
A40-18	41'-2"
A45-17	46'-6"
A45-19	46'-8"
A50-17	51'-5"
A50-19	51'-6"

**NOTE:** As mentioned, these tables apply only if you are going to erect a "standard" building on a "standard" foundation. If the building is a "special" model not listed in table 1, or if it has special features such as a side canopy, then the foundation may have to be modified.

**CAUTION:** If, for some reason, you want to modify the size of the foundation, remember that the width of the arches must remain the same. If the correct width for the arches is not maintained, the endwalls will not fit properly.

TABLE 2

APPROX. BUILDING LENGTH	NUMBER OF ARCHES	FOUNDATION LENGTH	APPROX. BUILDING LENGTH	NUMBER OF ARCHES	FOUNDATION LENGTH
20'	9	20'-8"	86'	42	86'-8"
22'	10	22'-8"	88'	43	88'-8"
24'	11	24'-8"	90'	44	90'-8"
26'	12	26'-8"	92'	45	92'-8"
28'	13	28'-8"	94'	46	94'-8"
30'	14	30'-8"	96'	47	96'-8"
32'	15	32'-8"	98'	48	98'-8"
34'	16	34'-8"	100'	49	100'-8"
36'	17	36'-8"	102'	50	102'-8"
38'	18	38'-8"	104'	51	104'-8"
40'	19	40'-8"	106'	52	106'-8"
42'	20	42'-8"	108'	53	108'-8"
44'	21	44'-8"	110'	54	110'-8"
46'	22	46'-8"	112'	55	112'-8"
48'	23	48'-8"	114'	56	114'-8"
50'	24	50'-8"	116'	57	116'-8"
52'	25	52'-8"	118'	58	118'-8"
54'	26	54'-8"	120'	59	120'-8"
56'	27	56'-8"	122'	60	122'-8"
58'	28	58'-8"	124'	61	124'-8"
60'	29	60'-8"	126'	62	126'-8"
62'	30	62'-8"	128'	63	128'-8"
64'	31	64'-8"	130'	64	130'-8"
66'	32	66'-8"	132'	65	132'-8"
68'	33	68'-8"	134'	66	134'-8"
70'	34	70'-8"	136'	67	136'-8"
72'	35	72'-8"	138'	68	138'-8"
74'	36	74'-8"	140'	69	140'-8"
76'	37	76'-8"	142'	70	142'-8"
78'	38	78'-8"	144'	71	144'-8"
80'	39	80'-8"	146'	72	146'-8"
82'	40	82'-8"	148'	73	148'-8"
84'	41	84'-8"	150'	74	150'-8"

# PACKAGE 1 (DOORWALL & ENDWALL) FOUNDATION BLUEPRINT

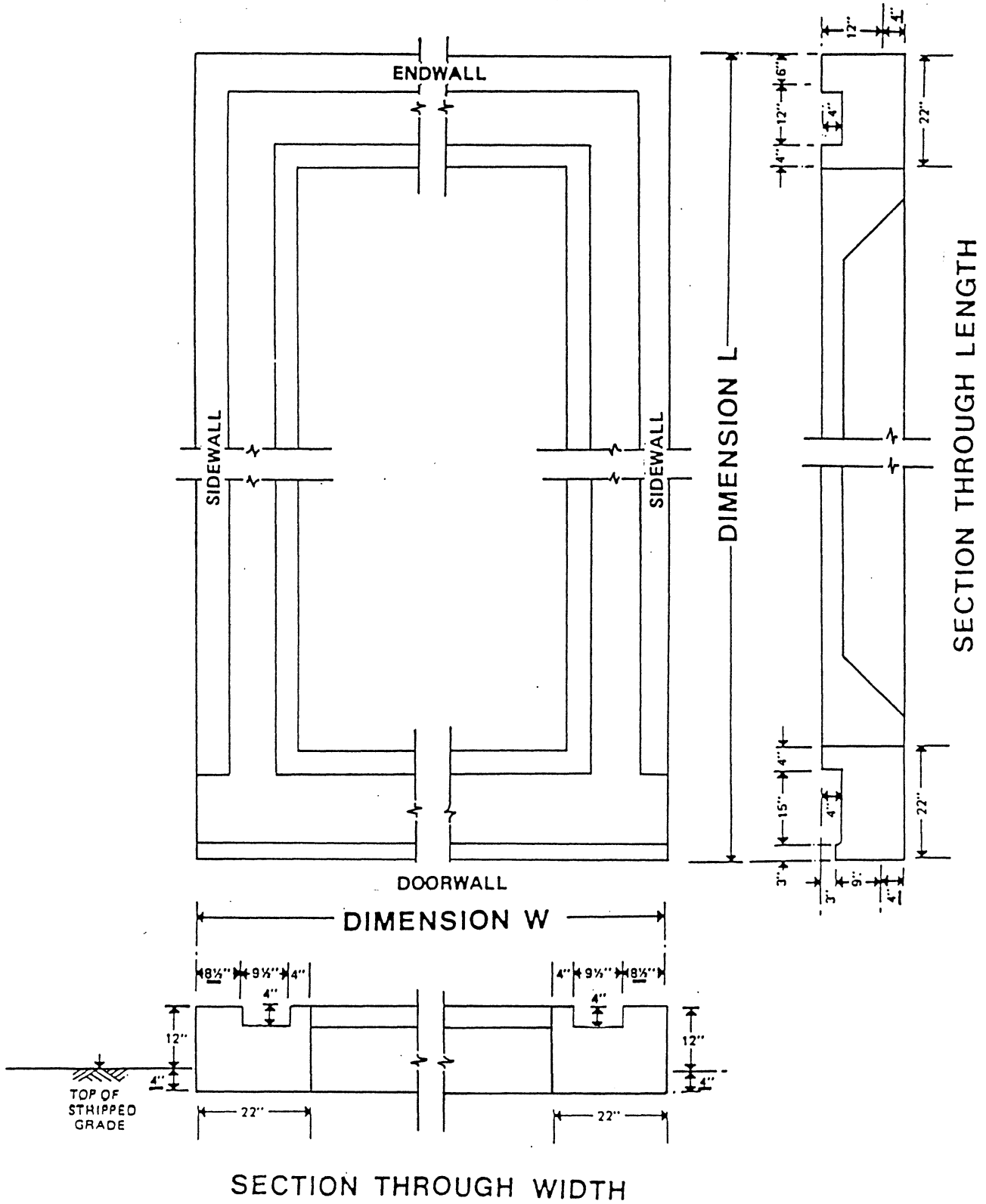



PACKAGE 2 (TWO DOORWALLS)

FOUNDATION BLUEPRINT

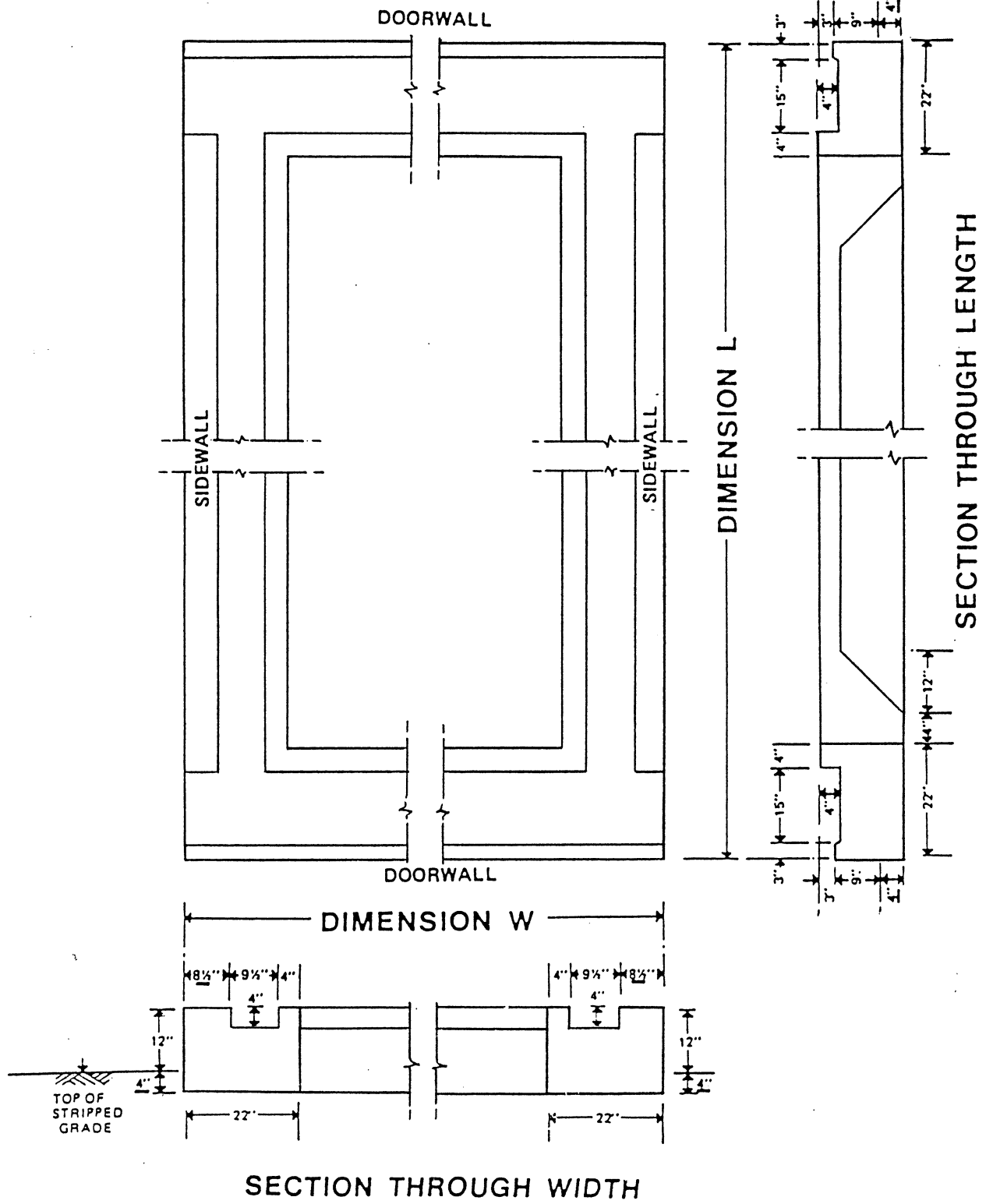

## PREPARING THE SITE

An important step in preparing a site for your ALPINE building is, of course, selecting a good location for the building. The following factors should be considered:

1. The building site should have adequate access roads.
2. Your building will probably be delivered on a 40-foot trailer. There should be enough room to position the trailer for unloading.
3. Check local by-laws and regulations for the required "setback" from adjacent structures, property lines and roadways.
4. Make certain there are no underground utilities on the site. If necessary, check with all utility authorities.
5. The condition of the soil should be suitable to support the building without excessively expensive foundations, and the site should be properly drained.
6. Check the grade of the site and the depth of the topsoil, to minimize the cost of stripping, grading and backfilling.
7. In areas of heavy snowfall, select an exposed location, away from trees and adjoining buildings, so that the wind can blow the snow off the roof, eliminating the need for manual removal.
8. Your ALPINE building should be oriented in the most favorable position, with regards to prevailing wind and rain, heat of the sun, and other weather factors.
9. Snow sliding off the side of the building should not obstruct traffic or access.
10. Leave enough room for future expansion or development.

When the right location has been decided upon, the site must be prepared for construction of the reinforced concrete foundation. If, as we strongly recommend, you have retained a civil engineer for the supervision of foundation construction, the engineer will specify, amongst other things:

1. Requirements for stripping and storage of the topsoil.
2. Quantity of backfill and nature of fill materials.
3. Compaction procedure for backfill or granular fill.
4. Drainage details.
5. Finished grades and profiles, and protection of banks.
6. Removal of stumps, roots, sod and other vegetable matter.
7. Disposition of existing foundations.
8. Diversion of existing buried utility services.
9. Special procedures for frozen ground.

## CENTERLINE OF BUILDING

As the first step towards construction of the foundation, the centerline of the building must be found. Note that the centerline will be used again when the arches are erected, so that it is important to work with accurate measurements. Use two wooden stakes and some builders' wire to establish the centerline. Drive the stakes into the ground until they are absolutely steady, then hammer a nail into the tops of the stakes and string the wire. The wire should be roughly 10 feet longer than the building will be (see fig.1).

NOTE: Do not use string or twine! Use only builders' wire, which is available in hardware stores, and which can be strung taut without stretching.

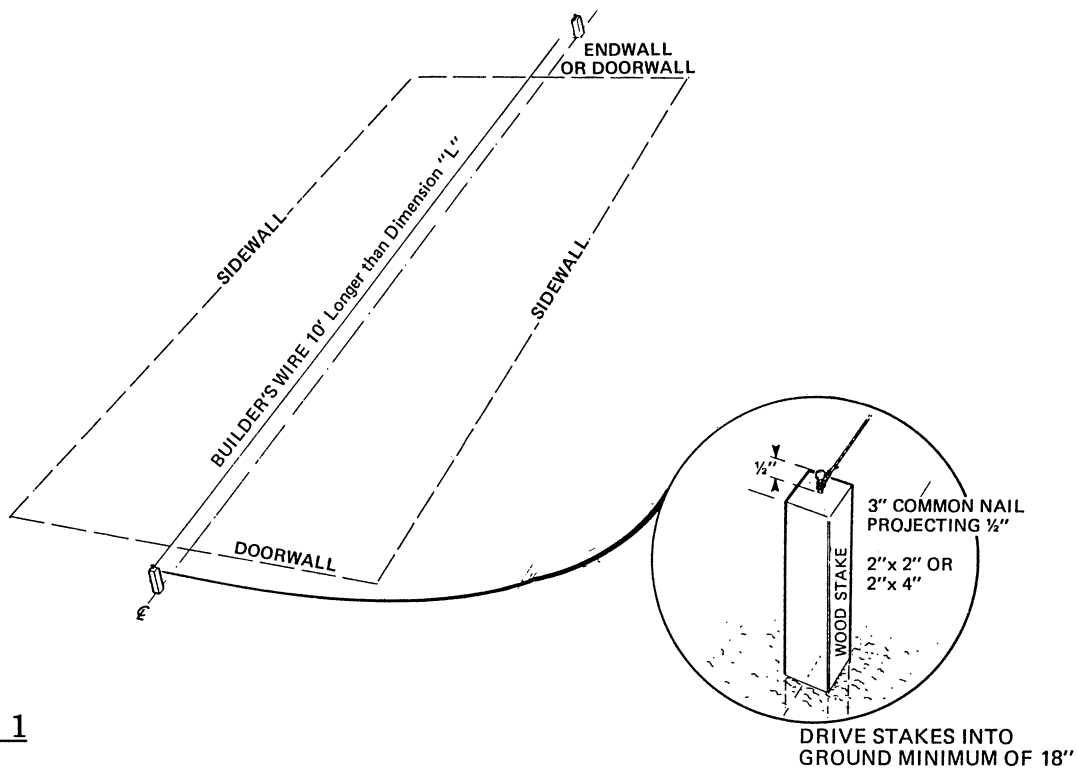

Fig. 1

## FOUNDATION OUTLINE

The next steps are very important for the successful completion of your ALPINE building. The foundation must be level as well as square, and have the correct dimensions, as shown in the tables on pages 6 and 7. Follow the steps outlined on the next page:

1. Roughly establish the four corners of your ALPINE building.
2. Construct two braced batterboards at each corner, each about 2 feet outward in both directions. To construct a batterboard, drive two stakes securely into the ground about 3 feet apart, and nail a horizontal 2" x 4" crossbar to the stakes, approximately 20 inches above grade. Then, brace each vertical stake by a diagonal brace nailed to a ground stake:
3. String wires, at right angles to the centerline and parallel with it, to mark the outline of your foundation. The points where these wires intersect are the outside corners of the foundation.
4. Check the main dimensions, corner to corner, and also check for squareness by measuring diagonally.

**CAUTION:** The outline of the foundation **MUST** be true and square. The arches will not fit properly on an incorrect foundation, and careful checking at this stage may save problems later on.

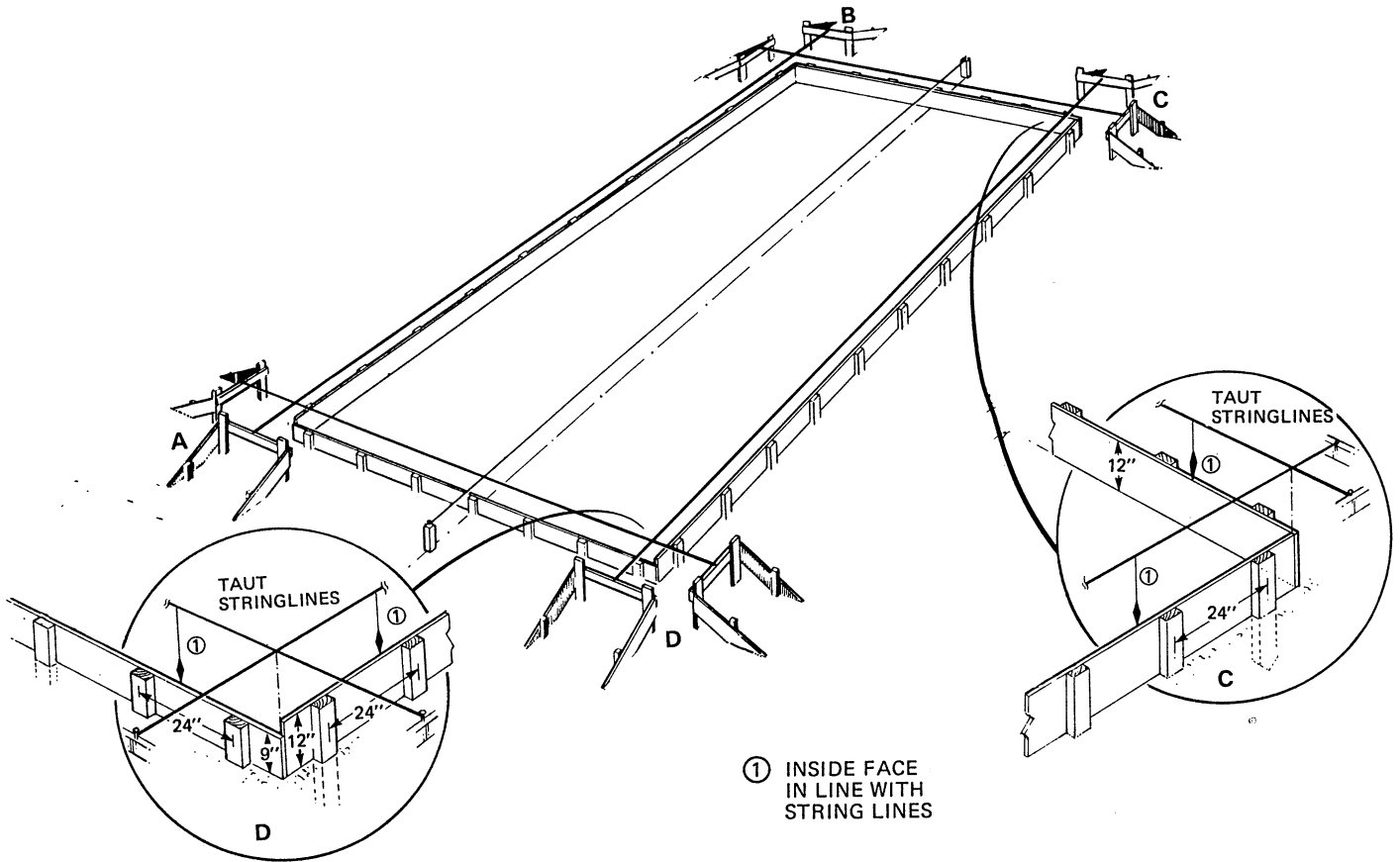

Fig. 2

## SETTING THE CONCRETE FORMS

The forms may be made out of plywood or board lumber, depending on price and availability. In general, the recommended procedure is to drive pointed 2" x 4" stakes into the ground and nail the formboards against the stakes. The outside forms must be aligned with the stringlines (see fig.2), and the inside formboards should be located so that there is a 22" space between the forms for the sidewalls and the endwalls (see fig.3).

**CAUTION:** Concrete is heavy - make the forms strong enough so that they will not collapse under the pressure of wet concrete. A formboard giving way while concrete is being placed is a costly nuisance.

The forms for the troughs (see page 16) should not be put in place until the reinforcing steel has been placed in the forms.

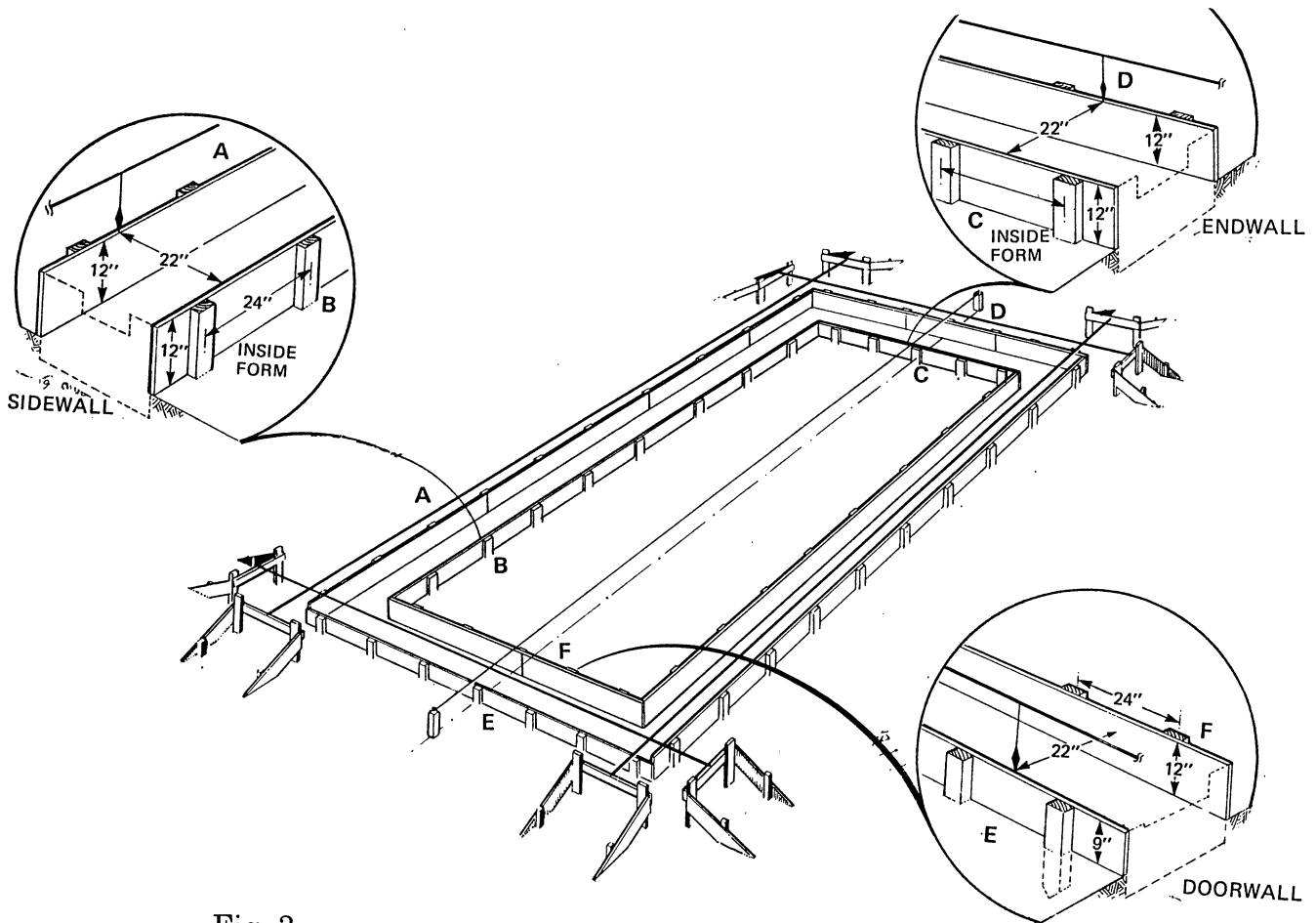

Fig. 3

## PLACING THE REINFORCING STEEL

Concrete without reinforcing steel cannot resist tensile stresses, and will tend to crack or fail completely under tensile loads. It is important to reinforce the concrete with steel bars made for this purpose. Reinforcing steel is a very hard material, difficult to cut or to bend. Moreover, the correct placement of reinforcing steel requires experience in this work, and we strongly suggest hiring a qualified contractor to do this part of the job.

NOTE: Reinforcing steel, if exposed to the atmosphere, is subject to rust and corrosion. To avoid this the steel must be protected by solid concrete of at least two inches in thickness.

It is very important to place the reinforcing bars in the right location, for maximum contribution to the overall strength of the foundation. Local conditions may require more steel, but in general we recommend four no.4 bars in the foundation perimeter, held in place by no.3 stirrups no more than two feet apart. A typical example of the arrangement of the reinforcing steel is shown in fig.4. This is just an example; your building may require different reinforcement.

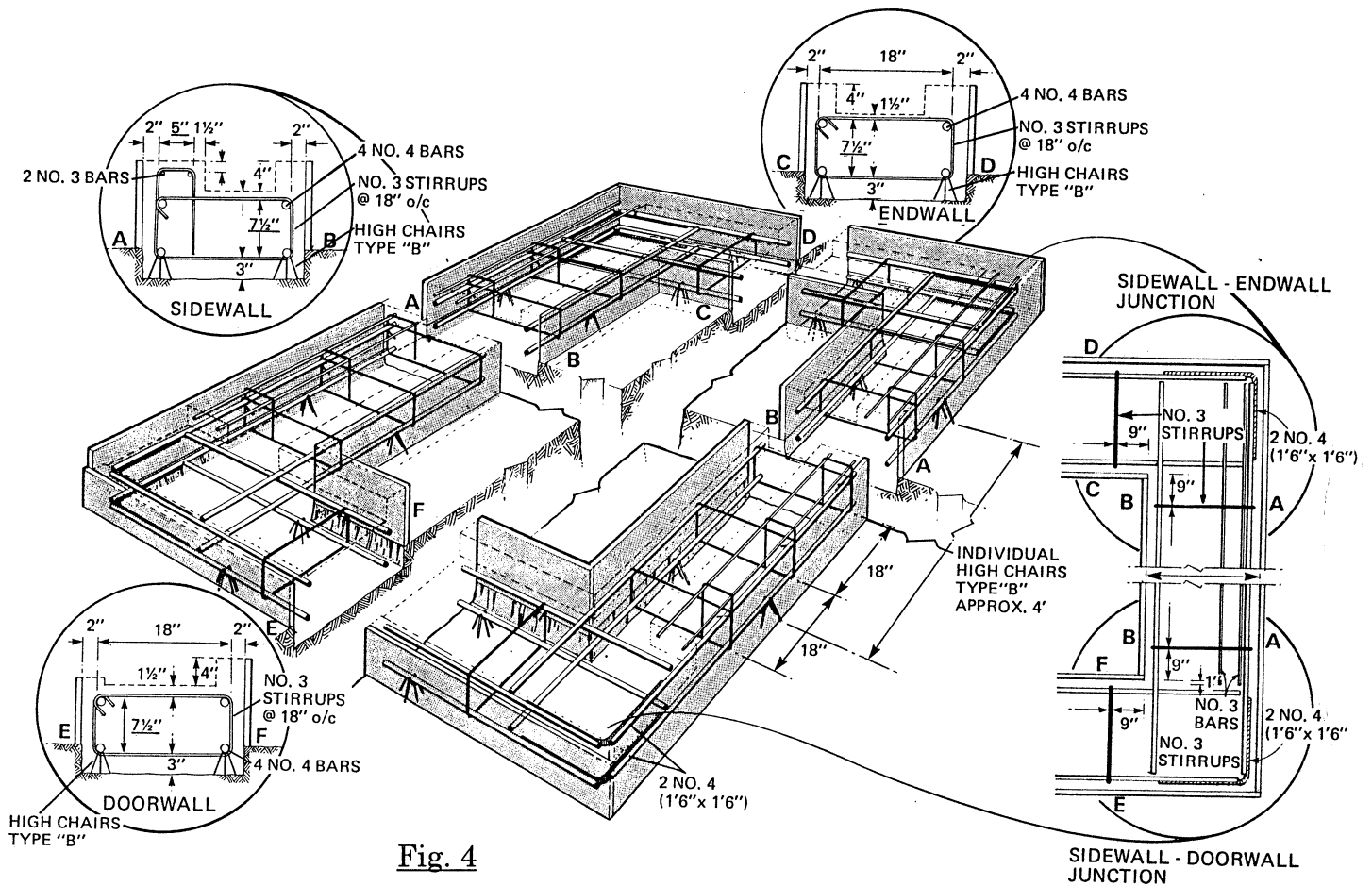

**Fig. 4**

The legs of the arches will want to spread apart, due to the weight of the arch, possibly increased by the weight of snow. This spreading force must be absorbed by the foundation, and without reinforcing bars the foundation could crack right down the middle. We strongly recommend the use of tie-bars from one side of the foundation to the other. These tie-bars can be made of no. 6 rebars, spaced about 6 feet apart, and they should be completely encased in concrete to prevent failure due to corrosion. Fig. 5 shows an example of how tie-bars can be installed.

NOTE: It is often necessary to splice tie-bars, due to the width of the building. The splices can be made with U-bolts; the bars should overlap by about two feet. The entire splice area, including the U-bolts, should be solidly encased in concrete.

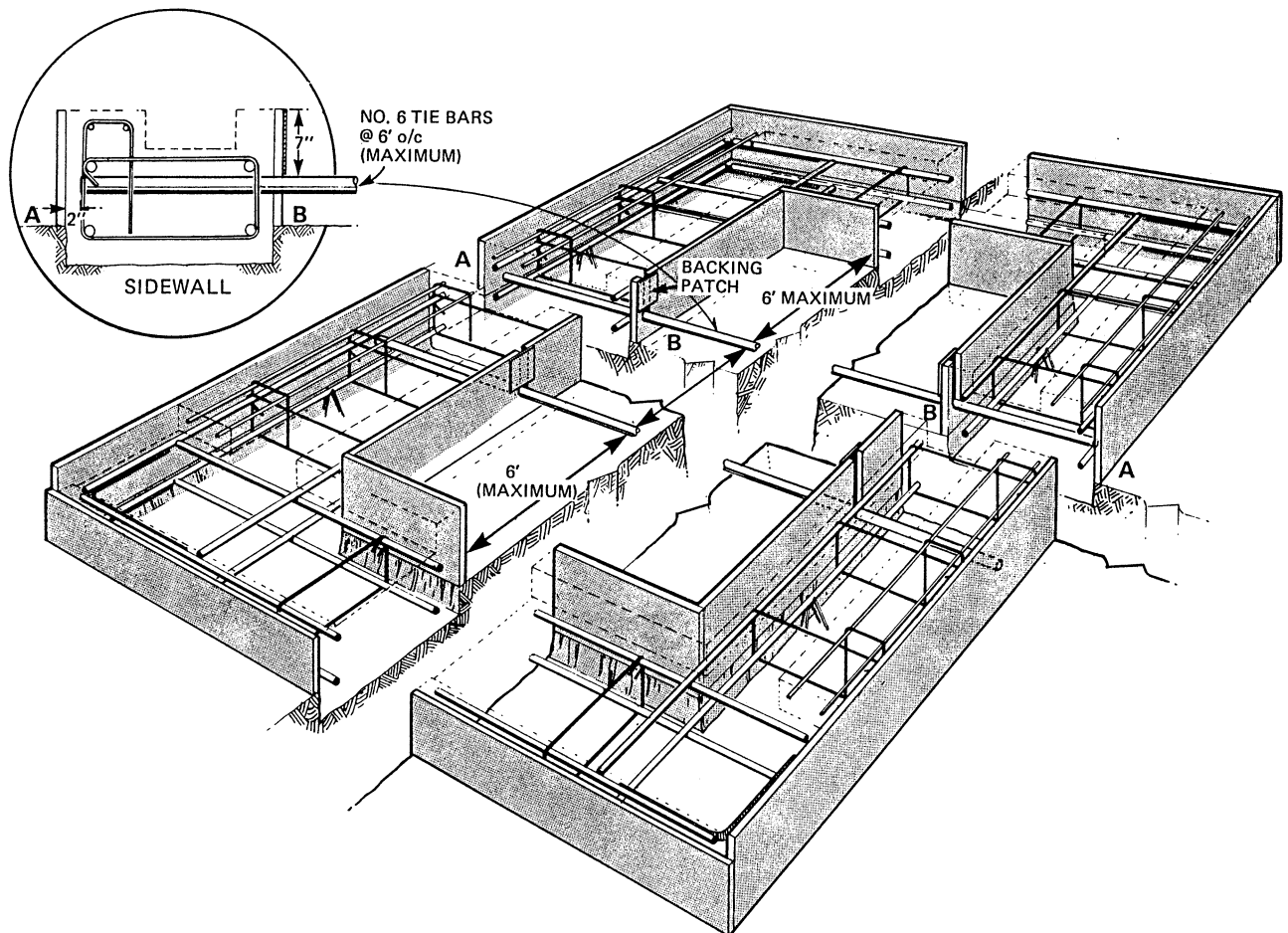

Fig. 5

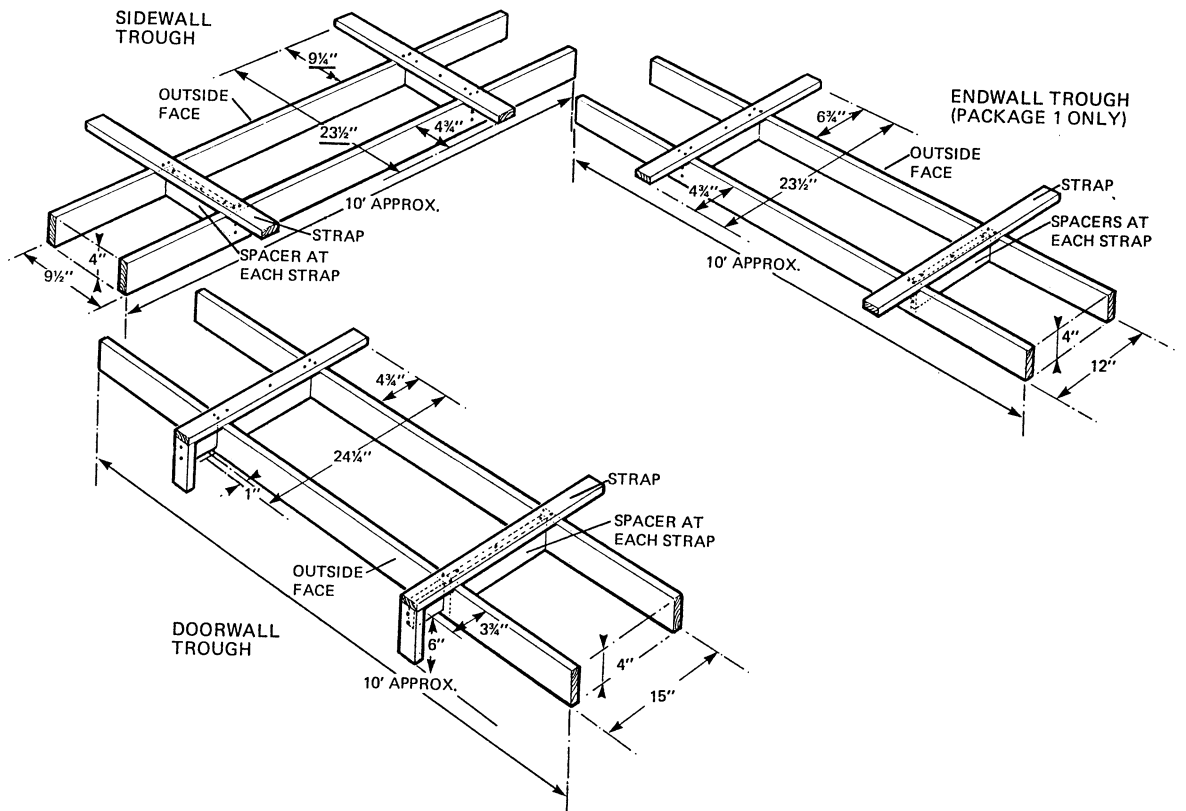

Fig. 6

### FORMING THE TROUGHS

When the reinforcing steel has been placed in the forms, the special forms for the troughs can be assembled and positioned. The diagram shows a simple way of assembling these forms (see fig.6).

**NOTE:** The bottoms of these forms are left open: it is always hard to get a good solid pour under a closed form, and air may be entrapped or voids may be left in the concrete. It is much better and easier to leave the bottoms of the forms open so that the concrete bottom surfaces of the troughs can be trowelled.

Check to see that the reinforcing steel does not come too close to any of the forms! If it does, the concrete protecting the steel bars from corrosion would be too thin to properly fulfill this function. Reinforcing steel should stay at least two inches clear of the forms, and any necessary corrections should be made at this time.



**PACKAGE 1  
FINISHED FORMWORK**

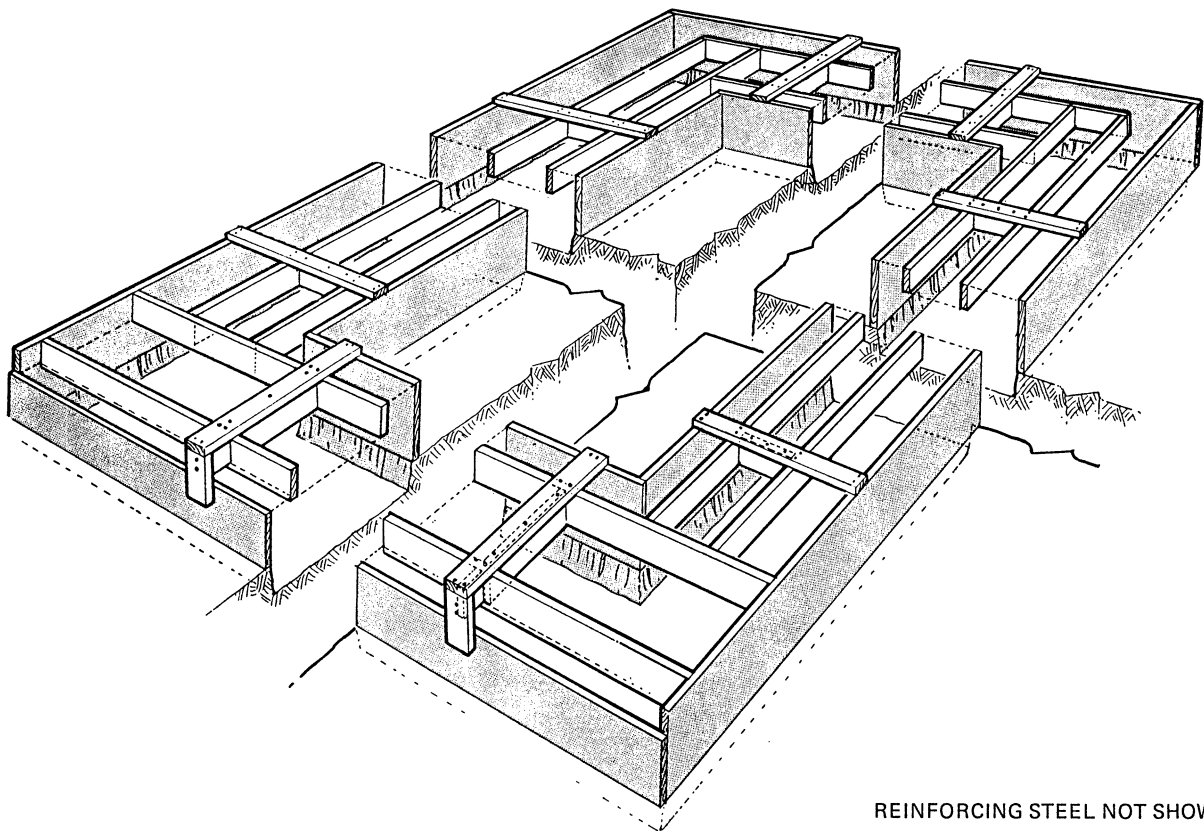

Fig. 7

FINISHING THE FORMS

For your convenience we have included a diagram of the finished formwork. The reinforcing steel has been omitted for clarity, as have some of the form details, but generally speaking; this is what your forms should look like (see fig.7)

The forms shown are for a "package 1" foundation. "Package 2" is quite similar, but the doorwall forms are duplicated at the other end.

Fig.8 shows a diagram of the foundation after the concrete has been poured and the forms have been removed, and fig.9 shows the details and the dimensions of the doorwall corner. These diagrams should be of help in checking the final dimensions of your forms.

## PLACING THE CONCRETE

We cannot possibly give complete specifications for the mixing, placing and curing of the concrete, as this depends on local conditions, availability, etc. In general, we strongly recommend using ready-mix concrete. For most applications, a 3000-psi/30 days mix with about 3 inches slump would be sufficient.

After the placing, the wire loops (not supplied with the building) should be inserted before the concrete sets (see fig.8). The first loop should be located 22 inches from the doorwall trough, and the remaining loops are inserted on 24-inch centers. These loops are used to tie down the building before grouting is completed, so that the arches won't be lifted out of the troughs by gusts of wind.

### PACKAGE 1 FINISHED CONCRETE

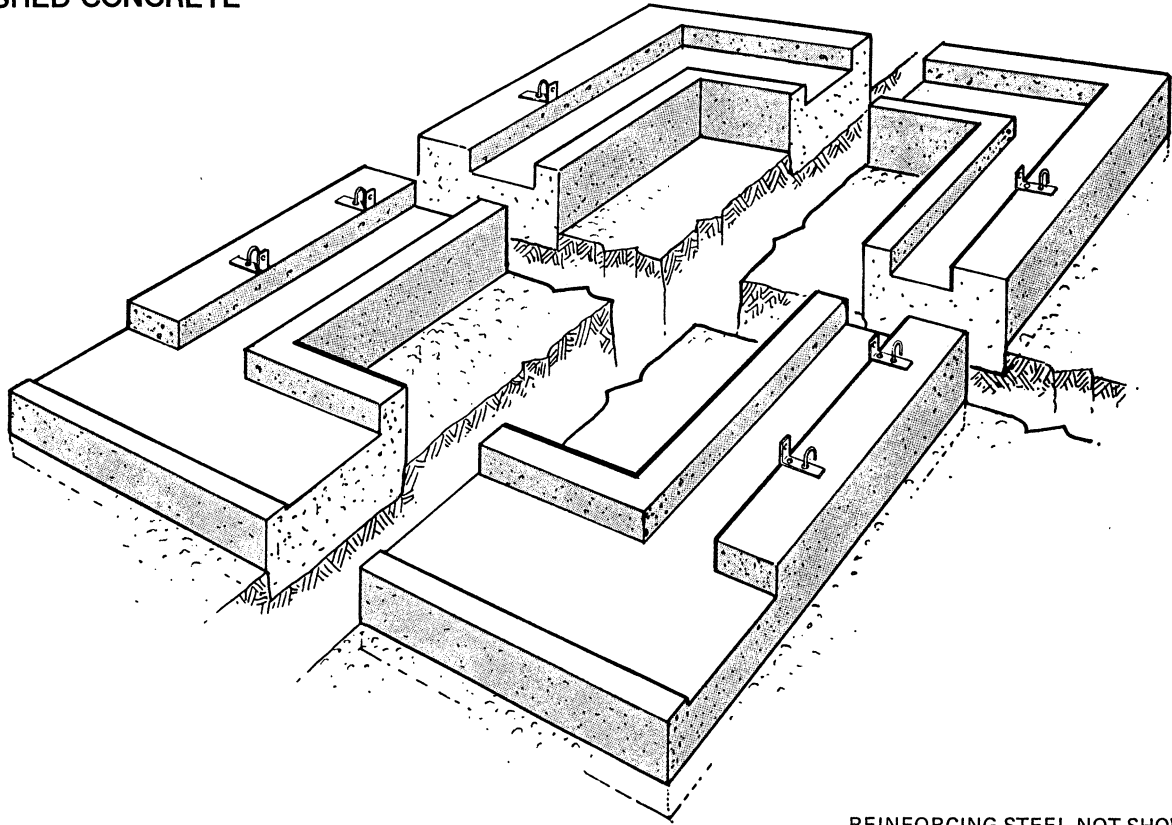

REINFORCING STEEL NOT SHOWN

Fig. 8

Note: Wire Loops not supplied with building.

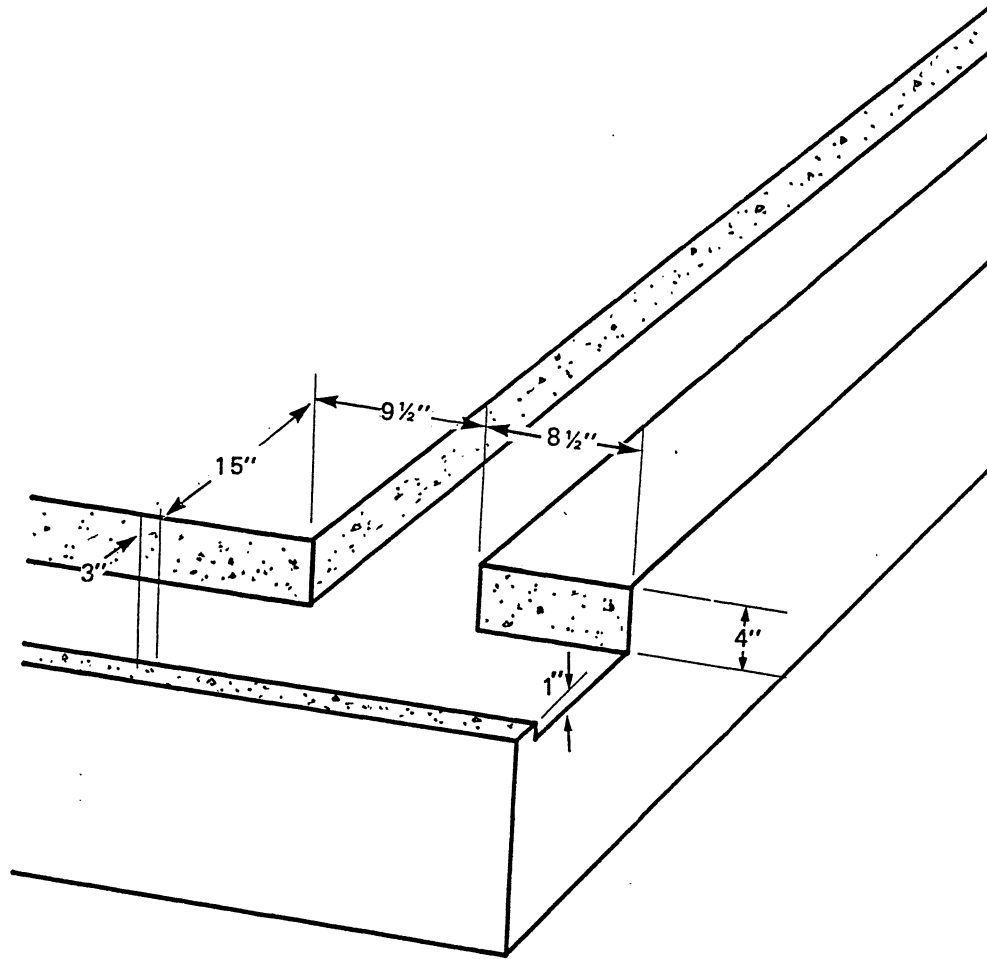

Fig. 9

After placing, the concrete may be compacted by spading or vibrating with mechanical vibrators, and protected in the usual way for outside work. It is recommended to keep the temperature above 50 degrees Fahrenheit (10 degrees Celsius) for at least three days; the concrete should be kept moist for a period of no less than seven days, to cure properly and develop strength.

## FINISHING THE FLOOR

Many people want to finish off the foundation by installing a smooth concrete floor, and we recommend a concrete floor as being useful. For the strength of the perimeter foundation, however, the floor is not required, and the space inside the foundation may be filled with crushed stone or other suitable materials.

NOTE: if a concrete floor will not be installed, it is still necessary to encase the tie-bars in concrete, to prevent failure due rusting of the bars. The encasement should measure no less than at least 6 by 6 inches.

Concrete floors are easily installed, and there are many ways of doing so. One recommended method is as follows:

1. When the tie-bars have been encased in concrete, remove all forms and construction rubble, and excavate between the tie-bars to a depth of 8 to 12 inches below the top of the foundation.

2. Place a granular fill (such as crushed limestone) to a depth of 4 to 6 inches below the top of the foundation.

3. Compact the granular fill as much as possible.

4. Carefully cover the fill with a layer of polyethylene sheeting, available for this purpose at building supply stores.

5. Install no. 6 wire mesh sheeting as reinforcement for the floor. The wire mesh should be raised 1 to 2 inches above the polyethylene sheeting. This can be accomplished by inserting small chunks of concrete under it.

6. Concrete can now be poured and finished by floating. The floor should be level with the top of the foundation in most cases.

NOTE: Further on in this guide some vertical dimensions are given, using the floor as a reference surface. It is assumed that the floor is flat, straight, and level with the top of the perimeter foundation. If this is not the case, allowances must be made in the dimensions.

## ESTIMATING CONCRETE

It is not always simple to estimate the quantity of concrete required for the foundation, and later for the second pour (grouting). The method below may help you. Simply take the length L (in feet) and the width W (in feet) of your ALPINE building, and insert those figures into the formulas:

FOR THE PERIMETER FOUNDATION:

$$L \times .162 =$$

$$W \times .151 =$$

TOTAL:	_____	CUBIC YARDS OF CONCRETE
--------	-------	-------------------------

FOR THE FLOOR:

$L \times W \times .014 =$	CUBIC YARDS OF CONCRETE
----------------------------	-------------------------

FOR THE GROUTING:

$$L \times .035 =$$

$$W \times .030 =$$

TOTAL:	_____	CUBIC YARDS OF CONCRETE
--------	-------	-------------------------

As an example, let us assume that we have a building 40 feet wide and 60 feet long. The formulas give us:

For the foundation:

$$60 \times .162 = 9.720$$

$$40 \times .151 = 6.040$$

Total:	_____	15.760 cubic yards
--------	-------	--------------------

For the floor:

$$60 \times 40 \times .014 = 33.600 \text{ cubic yards}$$

For the grouting:

$$60 \times .035 = 2.100$$

$$40 \times .030 = 1.200$$

Total:	_____	3.300 cubic yards
--------	-------	-------------------

The total amount of concrete for this building would be about 53 cubic yards. These figures are based on the dimensions shown in the diagrams, and they tend to be on the generous side: it is better to have a little concrete left over than to run short.

## ERECTION OF THE ARCHES

The arches of ALPINE buildings are the main components of the structure, acting as both the sidewalls and the roof. If properly erected, as outlined in the following pages, the building will be weathertight. We recommend, however, to apply caulking to all joints and seams in the arch structure, to avoid possible leakage problems in driving rain or other extreme weather conditions.

We supply, optionally, a superior brand of butyl caulking in strips, which can easily be applied. You may elect, if you wish, to use any good quality cartridge-type caulking, which may be purchased at a local hardware store and applied by means of a caulking gun.

It should be noted that there are two different methods of erecting the arches. The first method is the assembling of complete arches on the ground, and then raising them into position. This method is described in pages 24 to 35.

The second method is to assemble the arches in half-arch sections, raising the half sections separately and bolting them together to complete the arch. This method is described in pages 40 to 42.

In general, for buildings wider than 25 feet, we recommend the half-arch method. We suggest however, that you should read both methods carefully, and then decide on the one best suited to your available manpower and equipment.

**CAUTION: ALL BOLTS ARE PLACED INTO THE ARCHES AND LEFT FINGER TIGHT. DO NOT TIGHTEN WITH A WRENCH. ALL BOLTS ARE LEFT LOOSE UNTIL BUILDING IS COMPLETED.**

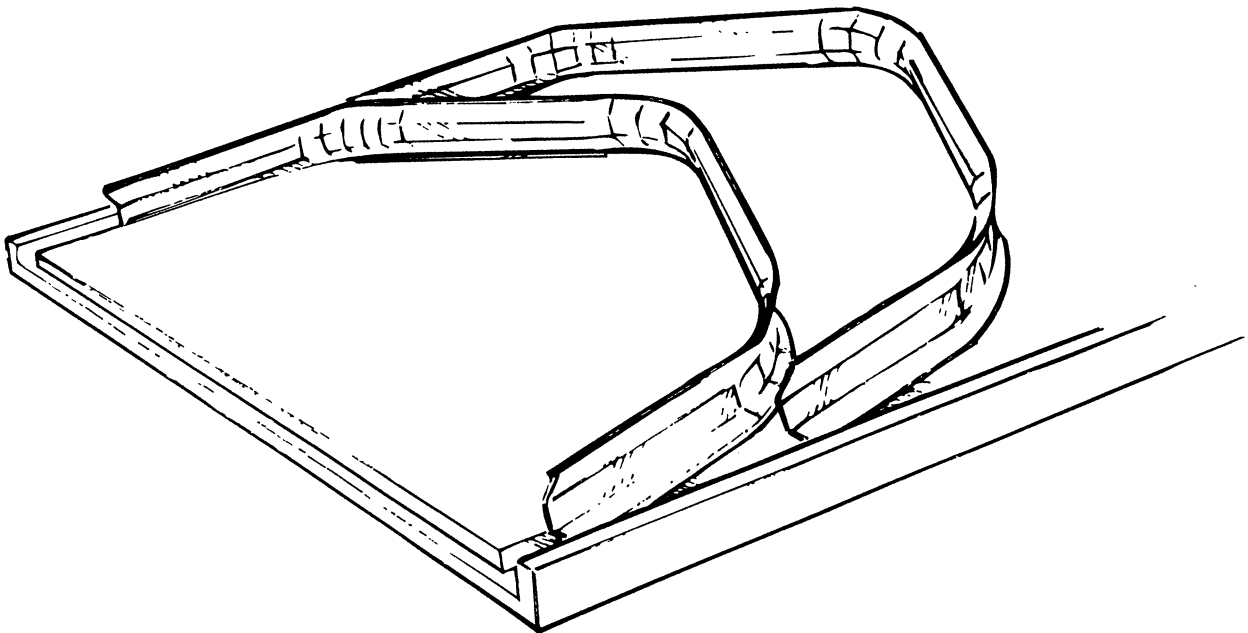

Fig. 10

The arches are assembled using two straight panels, two sharply curved eave panels, straight panels and one top curved peak panel (see fig.11).

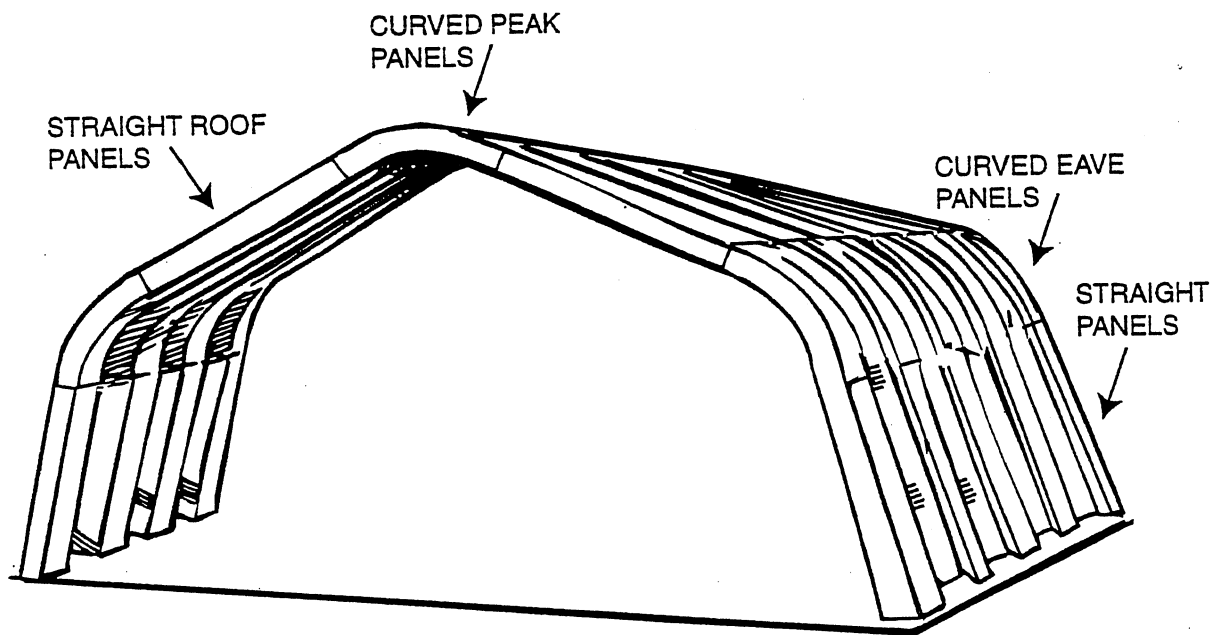

Fig. 11

The straight panels make up the top part of the arch and the walls. The eave part of the arch usually consists of a curved panel approximately 99 inches in length.

**ERECTION TIP:** Check the straight panels and select the ends that have the first line of bolt holes one inch (1") from the bottom edge. This is the end that must go into the concrete trough or base plate. The one inch (1") is measured from the center of the hole to the end of the panel.

To determine the number of panels in each arch for your building model, refer to fig. 12 on page 24 and 25, and table 3.

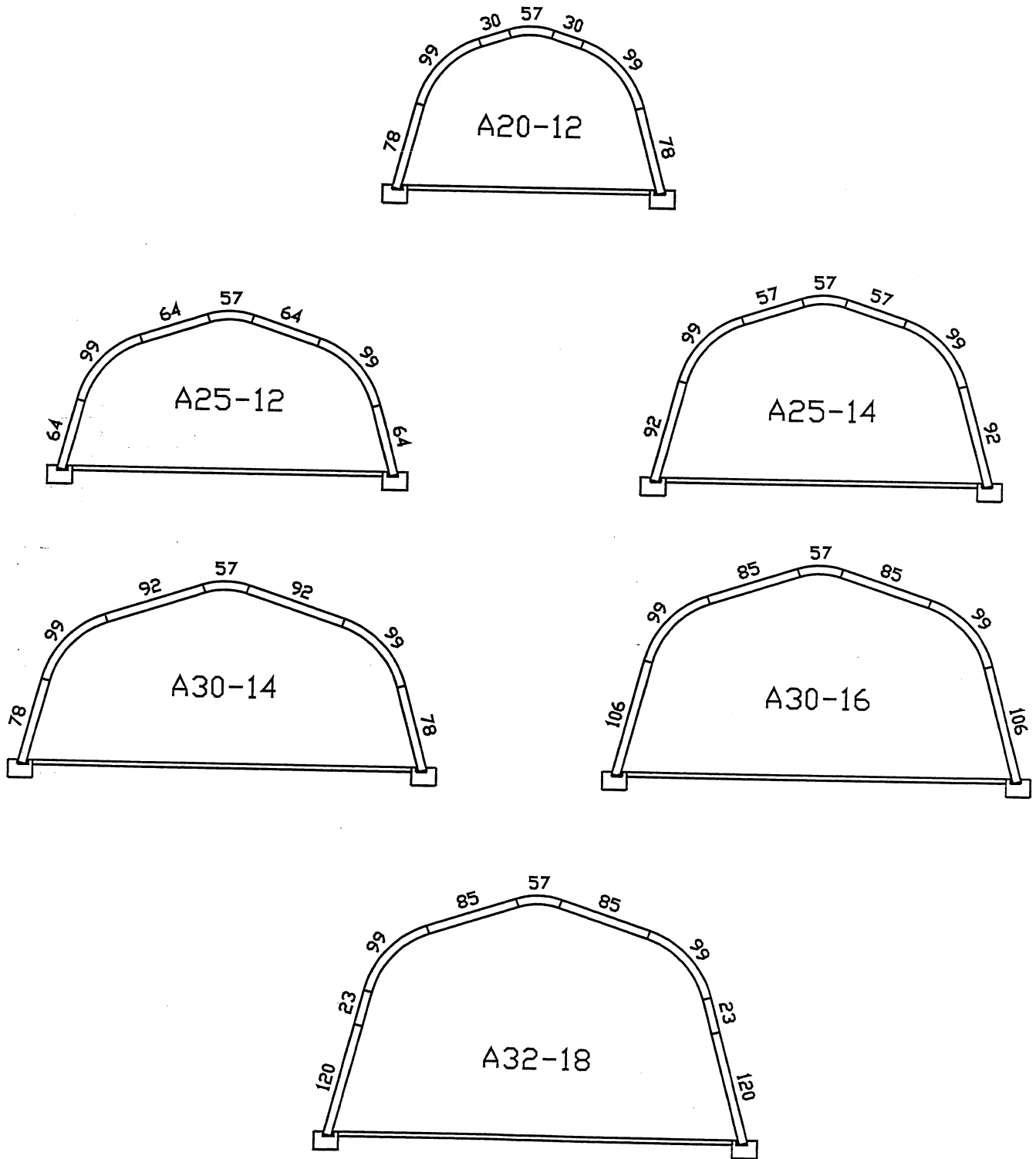

Fig. 12



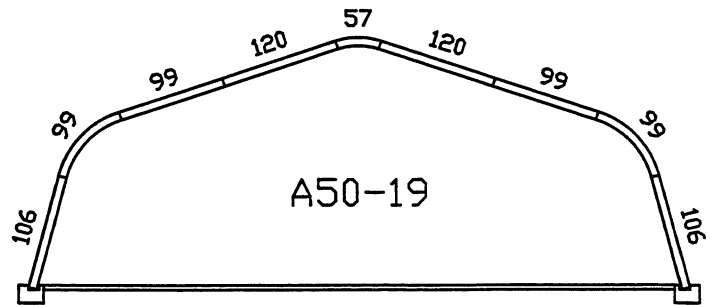
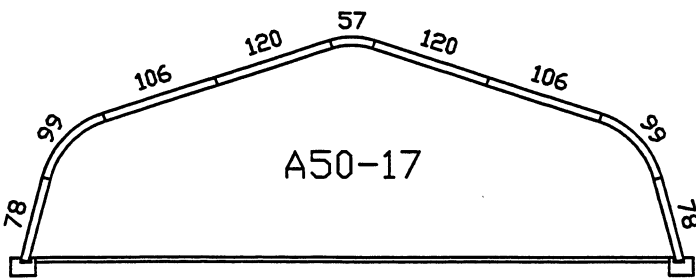
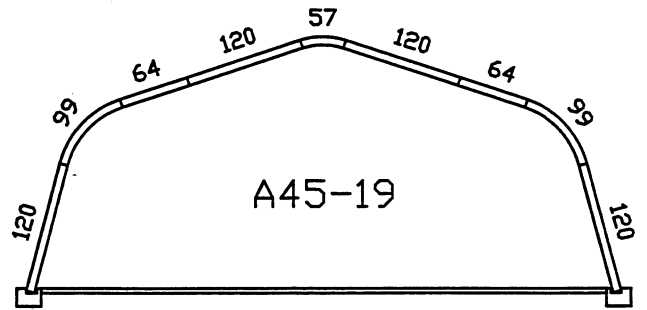
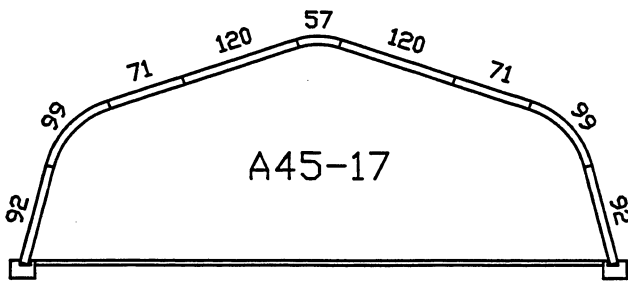
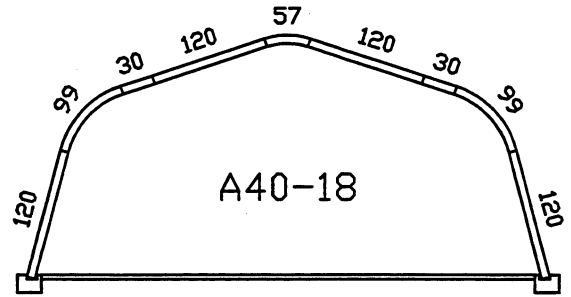
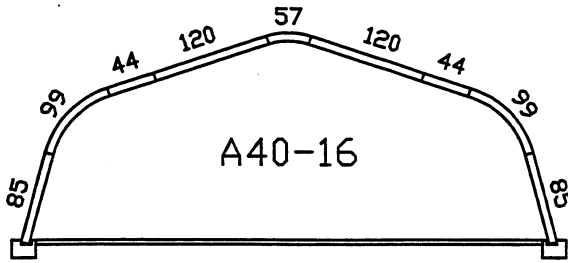
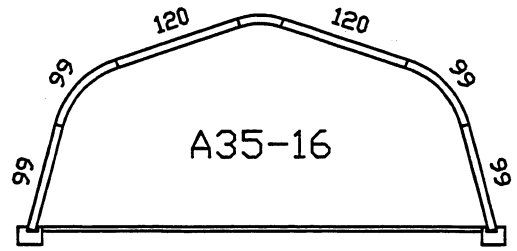
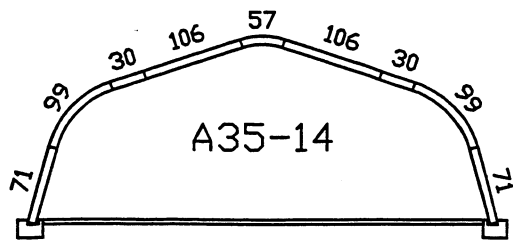

Fig. 12 (Cont.)

**CAUTION:** Check the number of panels per arch in table 3 before you begin bolting the panels together! An error in the number of panels in each arch will result in the wrong shape of the arches.

**TABLE 3**

<b>NUMBER OF PANELS IN EACH ARCH</b>				
<b>MODEL</b>	<b>STRAIGHT PANEL LENGTH (IN.)</b>	<b>EAVE PANEL LENGTH (IN.)</b>	<b>ROOF PANEL LENGTH (IN.)</b>	<b>PEAK PANEL LENGTH (IN.)</b>
A20-12	78	99	30	57
A25-12	64	99	64	57
A25-14	92	99	57	57
A30-14	78	99	92	57
A30-16	106	99	85	57
A32-18	120+23*	99	85	57
A35-14	71	99	106+30*	57
A35-16	99	99	120	57
A40-16	85	99	120+44*	57
A40-18	120	99	120+30*	57
A45-17	92	99	120+71*	57
A45-19	120	99	120+64*	57
A50-17	78	99	120+106*	57
A50-19	106	99	120+99*	57

\*Roof or straight portion consists of two panels, a long panel and a short panel. The two panels should be alternated in location in order to stagger the lap between successive arches.

NOTE: A double bead of caulking, if used, should be applied, as shown in fig.13, before the panels are joined together.

NOTE: When joining the panels to create a full arch, it is important to properly overlap the panels, so that rain will flow easily down the arch without leaking into the joint (see fig.14).

The panels are bolted end-to-end. It is usually easier to insert the bottom bolts first and tighten them a little, to "nest" the two panels. Next, the bolts in the sides are inserted. It is often necessary to use a drift pin in one of the side holes to make the adjoining side hole "line up" (see fig.15). The drift pin should be used with care, to avoid ripping the sheet around the hole, as this could result in leakage. It is not always an easy job to insert the bolts in the side holes, but with some experience and a reasonable amount of care a strong and leakproof joint will result.

NOTE: If a bolt hole is accidentally ripped or torn by the drift pin some caulking should be applied around the bolt head to seal the hole.

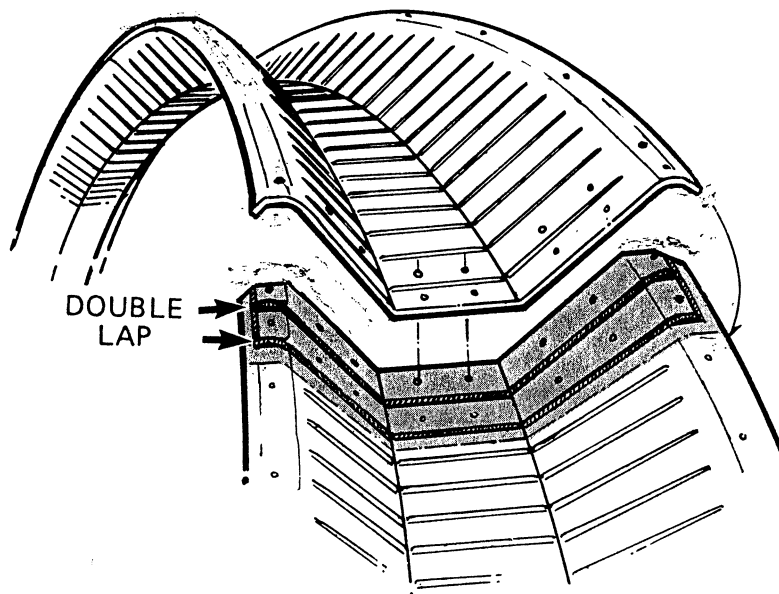

Fig. 13

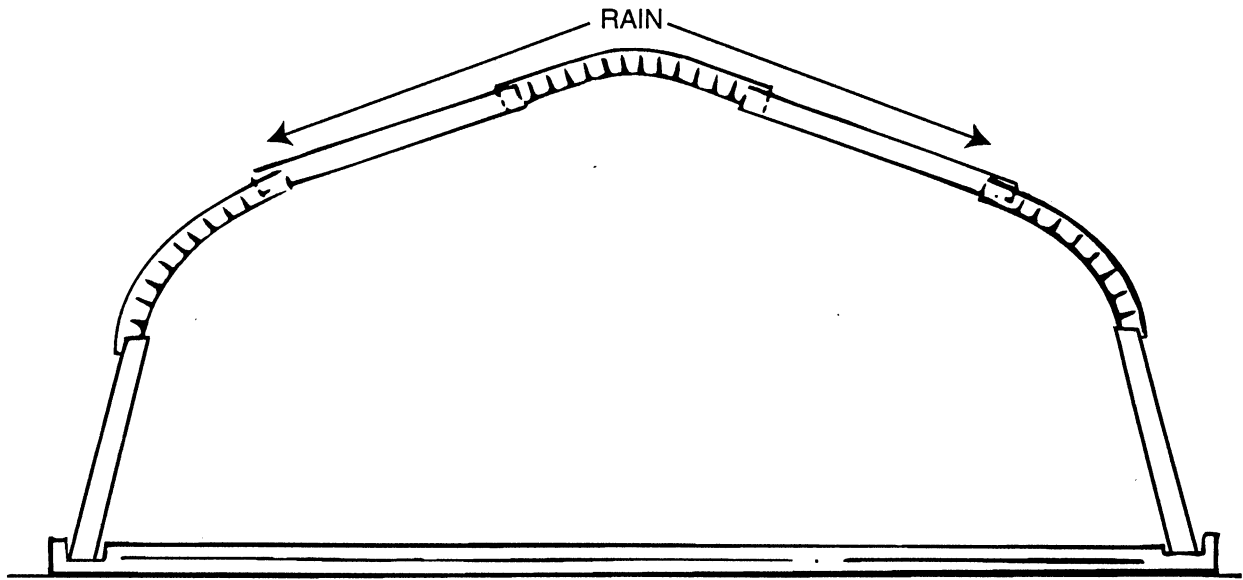

Fig. 14

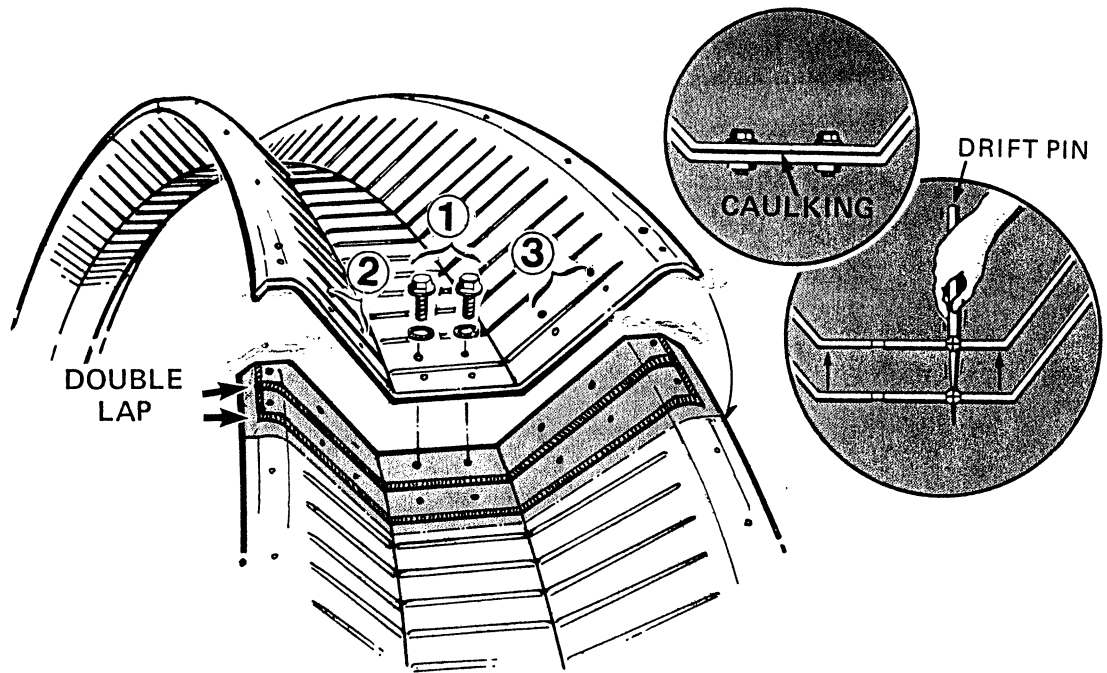

Fig. 15

NOTE: All bolts are placed into the arches and left finger tight. Do not tighten with a wrench. All bolts are left loose until building is completed.

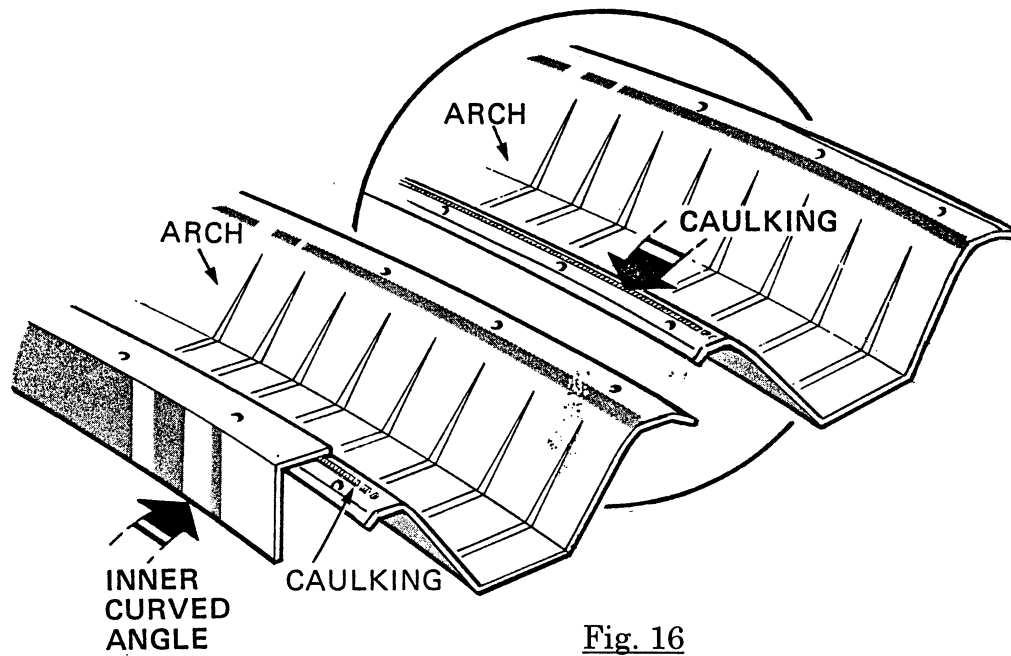

Fig. 16

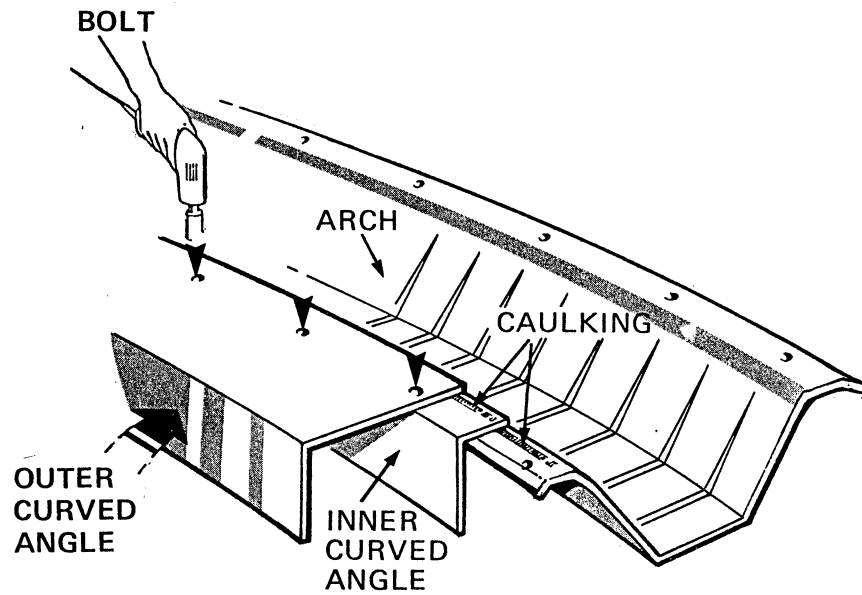

Fig. 17

Special care should be taken erecting the first arch, as single arches are very flexible and can be hard to control, and yet distortion must be avoided. It is recommended to bolt on the curved angles before raising the first arch, as this adds to the stiffness of the arch.

NOTE: The curved angles are If shipped as a curved bundle. The bundle contains "inner' and outer" curved angles. The inner curved angles are narrower than the outer ones. Take the bundle apart and compare the quantities with your packing-list, to make certain that you have correctly identified all pieces.

A piece of inner curved angle is now placed into position on the arch, as shown in fig.16. Make sure to apply a strip of caulking, if used, between the arch panel and the inner curved angle. It is good practice to wipe the edge of the arch panel with a rag before applying the caulking, as the arch panels are protected by a thin film of special oil, which may prevent the caulking from sticking to the steel. Do not insert any bolts at this time - first take a piece of outer curved angle, apply a strip of caulking on top of the inner curved angle, between the bolt holes and the outside edge, and position the outer curved angle on top, as shown in fig.17. Align the bolt holes in the three sheets with the help of a drift pin, insert the bolts and tighten them.

NOTE: The same rule applies for overlapping the curved angles as for the arches: all joints must be caulked and the overlaps should allow for proper rain run-off (see fig.18).

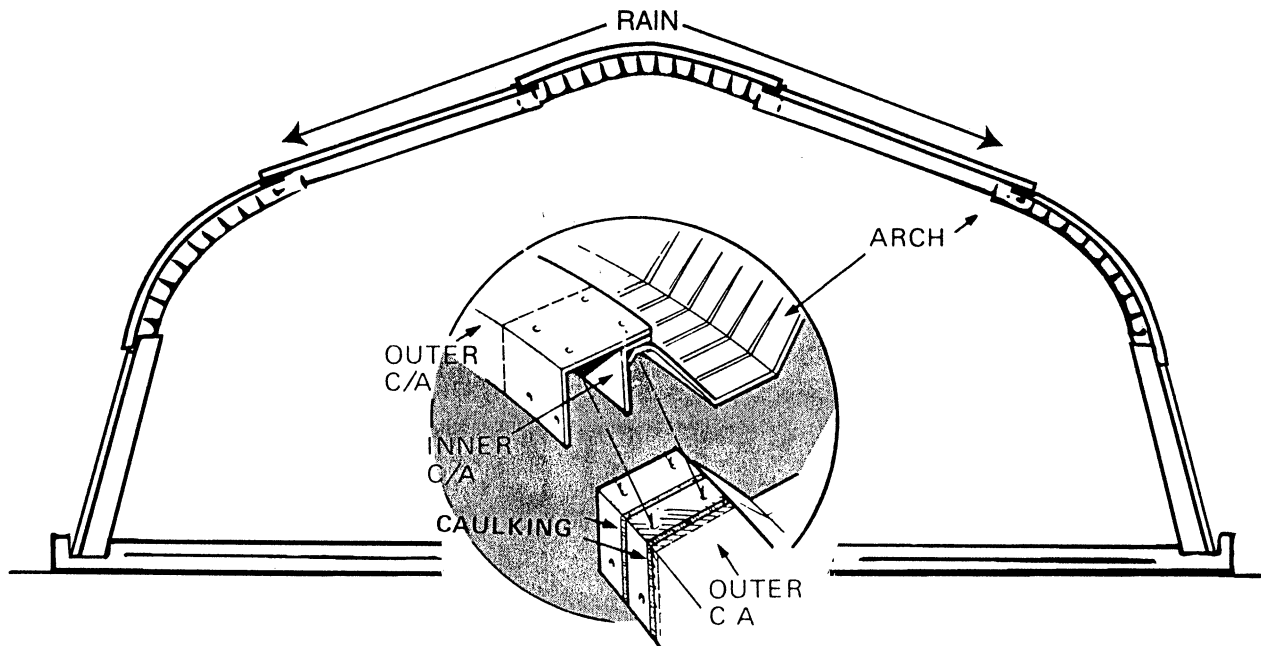

Fig. 18

Again, the first arch is the most difficult to raise, and all precautions should be taken to avoid damage or injury. It is especially important to avoid twisting the arch, as this usually results in permanent damage to one or more panels. It is generally better to raise the arches manually, as the use of a crane often results in distortion of the arch and subsequent buckling of a panel. The use of scaffolding is strongly recommended. Rental scaffolds are available in many areas, but homemade scaffolding may be used.

**CAUTION:** All scaffolds and platforms should be properly "tied off" or otherwise secured against overturning. Provide the necessary handrails for your crew and make certain that sturdy-ladders are available. It is especially important to secure scaffolding when the arches are being pulled up into position.

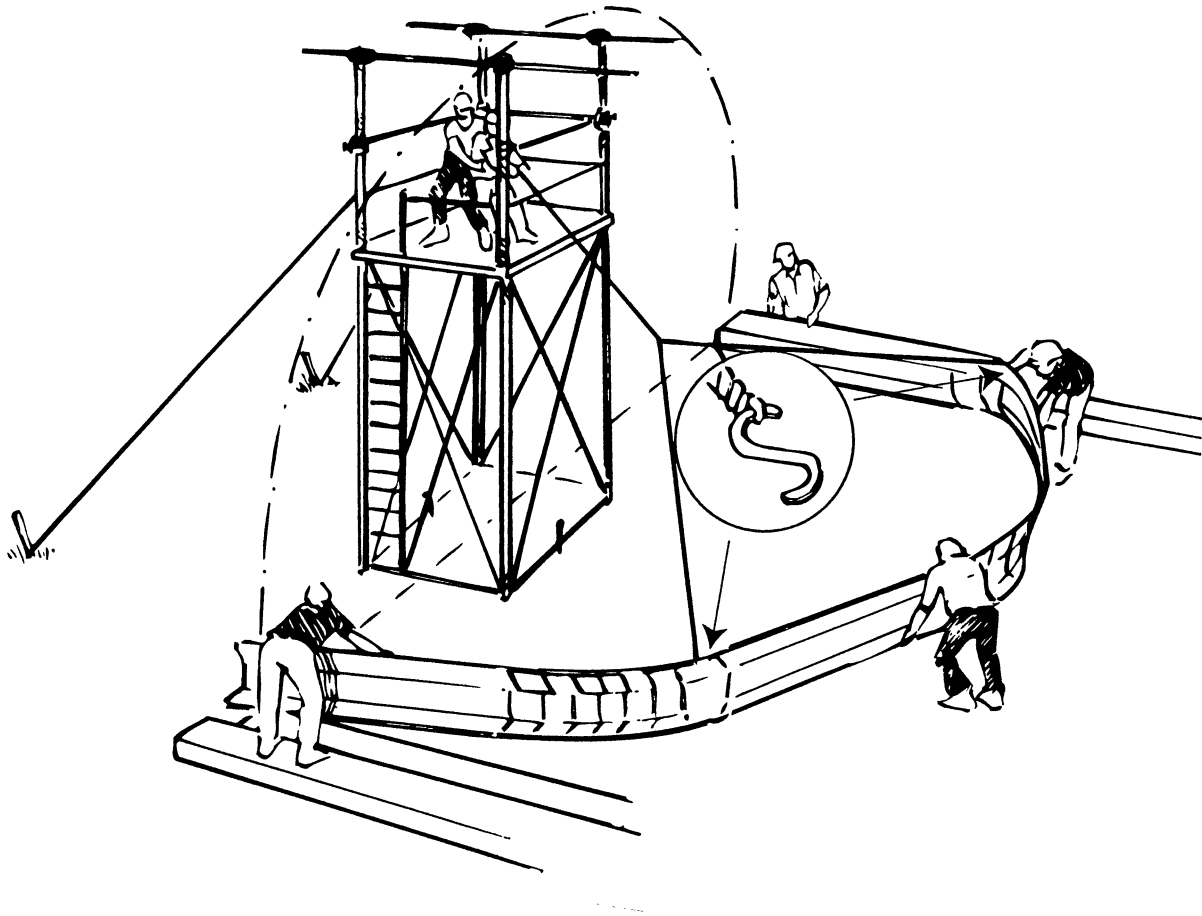
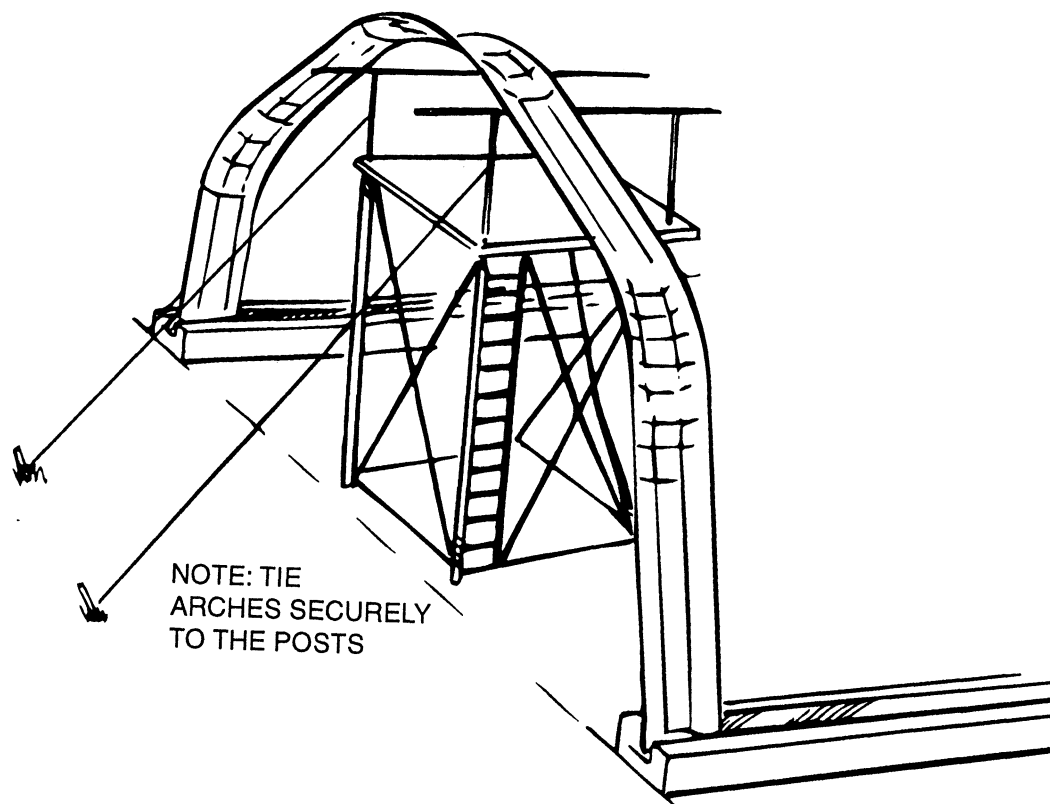

Fig. 19

Putting up the first arch may be done as follows:

1. Place two men on the scaffold, with ropes connected to the arch.
2. Have one man at each end of the arch to guide the arch into the foundation trough, and to lift the end as the arch comes upright, to avoid bending the corners.
3. Depending on building size and available manpower, station three or four men along the circumference of the arch, to help lift and control the arch. Provide these men with two-by-fours to enable them to push up the arch when it is raised.
4. Attach ropes to the arch by means of "S" hooks or by looping the rope around the arch. Use two ropes about 10 or 12 feet apart, or use a spreader, as shown in fig.19.
5. One person should be in charge of the hoisting operation, to avoid confusion.
6. The entire crew should slowly and carefully lift the arch off the ground. The two men stationed at the ends should lift the corners clear of the concrete and guide the ends in place.
7. The rest of the crew should lift the arch, taking care to keep it as straight as possible. When the top is about 6 feet off the ground, the man at the top takes his two-by-four and continues to support the arch.

Fig. 20





NOTE: It is often helpful to nail two short boards to the upper end of the two-by-fours, making a fork to support the panel edge.

8. As the arch continues to rise, others take their two-by-fours in turn, so that the arch is supported along its perimeter at all times.

9. Once the arch reaches the vertical position, it should be properly secured to the scaffold or by guy wires tied to stakes driven into the ground (see fig.20). This is very important, especially when it is windy.

CAUTION: It is not safe for a man to stand on top of a single arch, as the arch, by itself, cannot support this load.

Once the first arch has been raised it should be positioned at the correct location in the trough. The distance from the end of the sidewall concrete to the center of the hole in the arch panel should be exactly 2 inches, as shown in fig.21. This is important for the location of the endwall at a later stage.

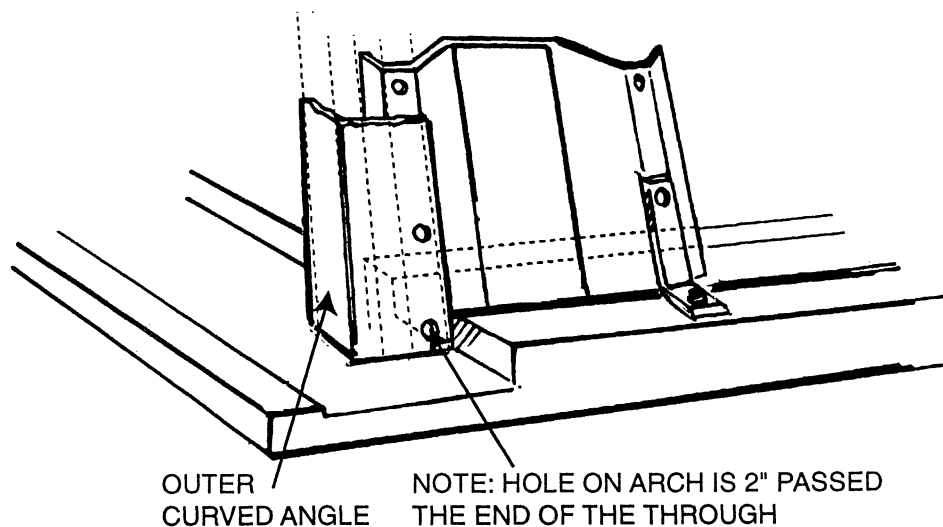

Fig. 21

Before the next arch is raised into position, caulking (if used) should be applied along the entire length of the arch (see fig.22). Be sure to wipe the underside of the edge to remove the protective soil, so that the caulking will stick to the steel when the arch is placed upright. Apply the caulking in a continuous strip between the outside edge of the panel and the bolt holes.

NOTE: It is a good idea not to wipe the oil from the top of the previous arch. When the next arch is placed in position, a little oil on the rim of the previous arch makes it easier to slide the arches back and forth to line up the bolt holes.

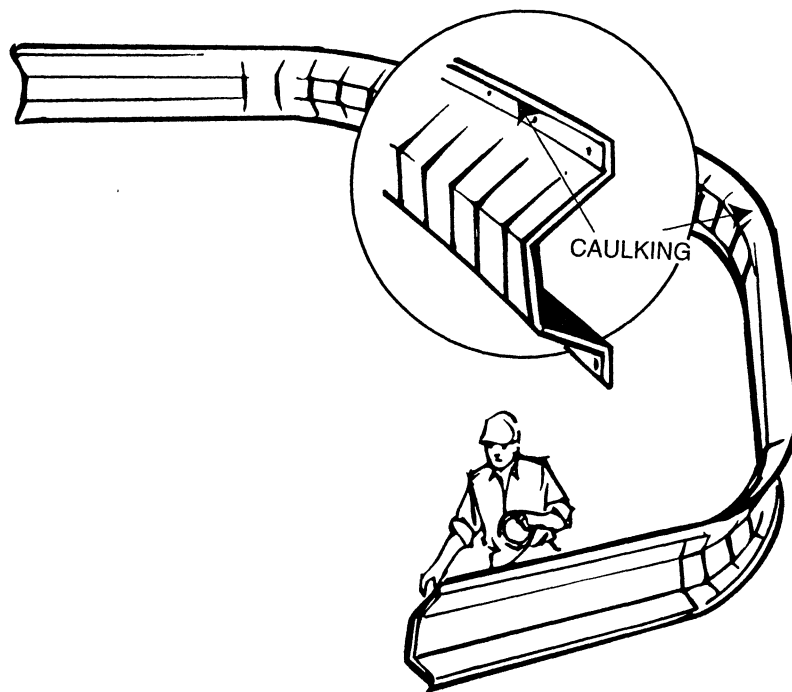

Fig. 22

The next arch is raised in the same manner, and lifted over the rim of the previous one (see fig.23). Drift pins are used to align the bolt holes so that the bolts can be inserted.

NOTE: Use the drift pins carefully, to avoid tearing or elongating the bolt holes, as this may result in leaks. It may take some practice, but it is quite possible to insert all bolts without damaging the panels.

At this stage only every third or fourth bolt needs to be inserted (see fig.24). It is generally easier to insert the first bolt at the peak of the arch and then work your way down the sides. Although this is possible for one man to do this by reaching around the panel, it is much easier to work in two-man teams, with one man on the outside and one on the inside of the arch.

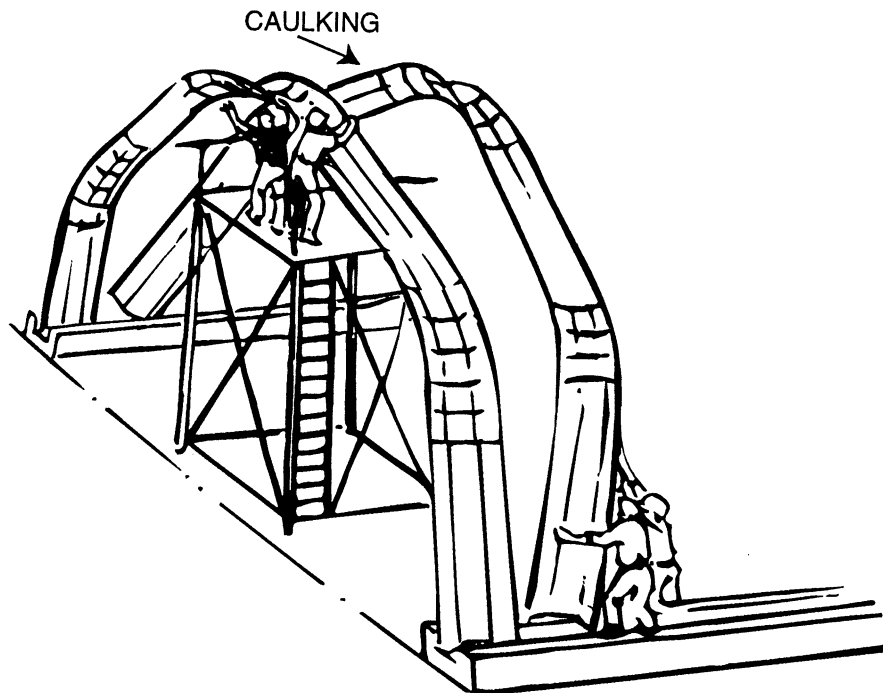

Fig. 23

As the arches are erected they should be secured, not only against being blown over by a sudden gust, but also against being lifted out of the troughs. Especially when many arches have been erected and joined together, a strong wind can generate enough suction to lift several arches out of the trough, possibly creating extensive damage. It is important, then, to secure the arches to the foundation, for example as shown in fig.25.

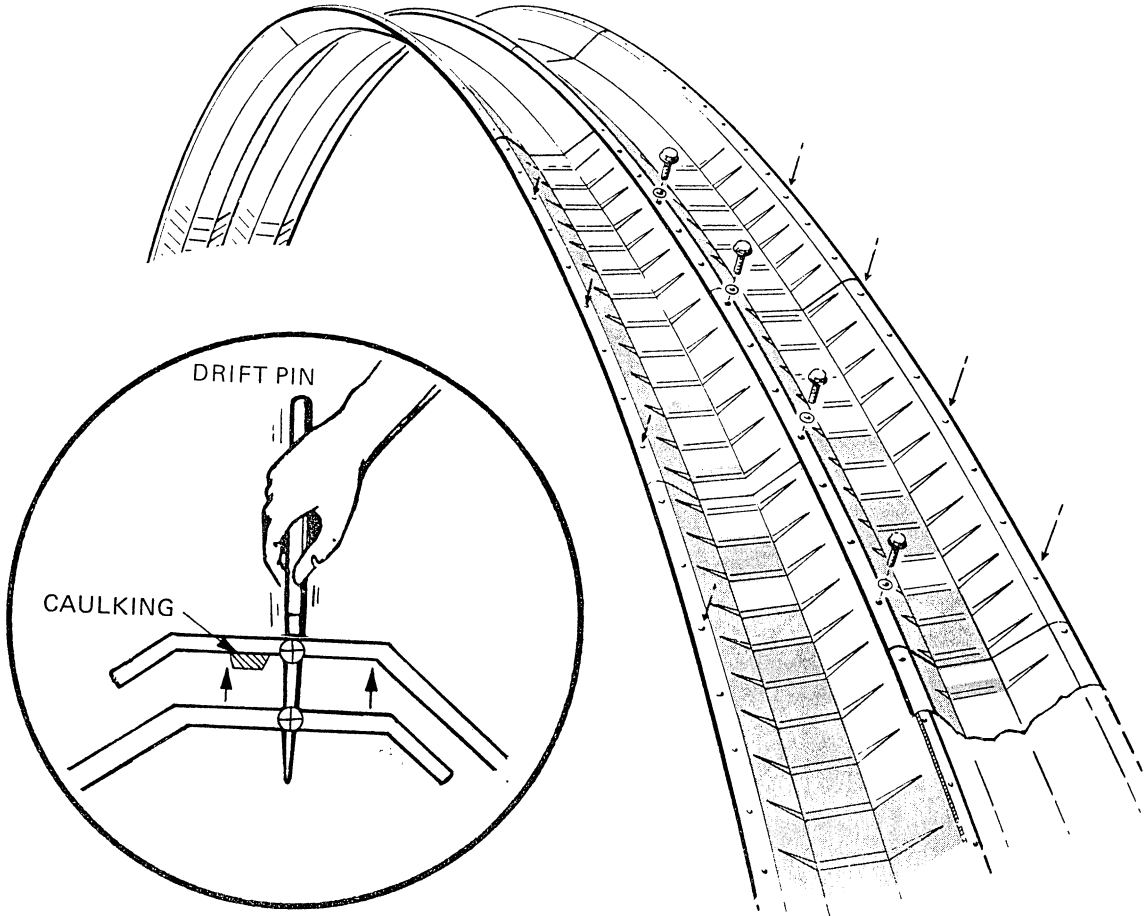

Fig. 24

At this stage, the arches are still very flexible. It is necessary to check the shape of the arch and especially the length of the building to make certain that the arches are not "spreading" (growing in length). The dimensions from bolt hole to bolt hole should be 24 inches, as shown in fig.26. This dimension should be checked regularly, on both sides of the building as well as at the peak. If the structure tends to spread, it can be adjusted by pushing back on the arch sections. This is not difficult if it is done a few arches at a time, as shown in fig.27, and it should not be overlooked: if the entire building spreads and is not checked before all arches have been raised, it may be very difficult to bring it back to the proper size, and this, in turn, may make it impossible to install the rear endwall in its trough. We ship metal strapping angles with each building (usually packed with the endwall panels) and this strapping is punched at 24 inch centers. Three pieces of strapping should be bolted onto the first arches, and as the erection proceeds three more pieces are bolted on (see fig.28 and fig.29).

NOTE: Once all the arches are erected, the arch strapping should be removed to prevent trapping snow accumulation.

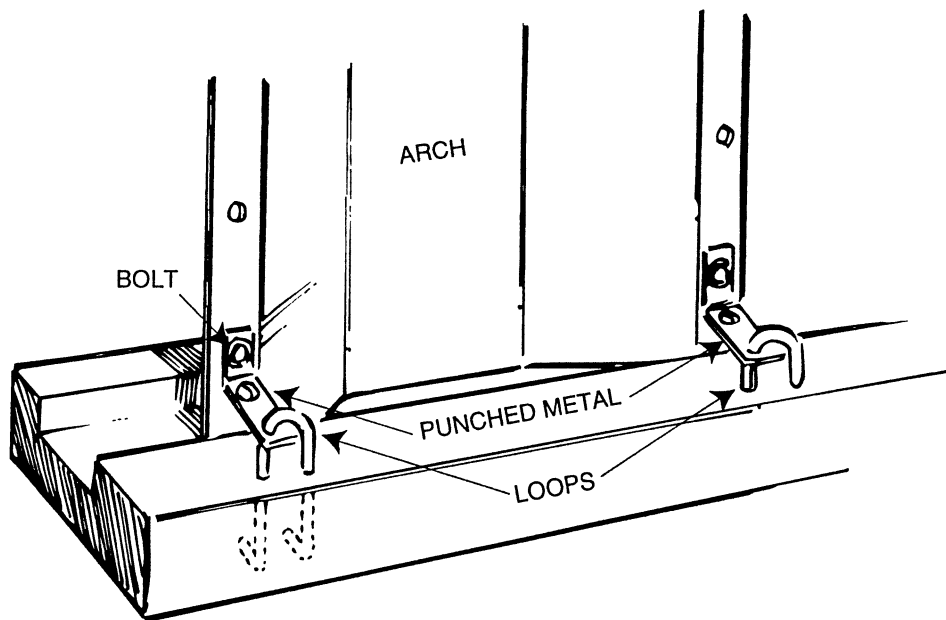

Fig. 25

NOTE: Wire loops and punched metal not supplied with building

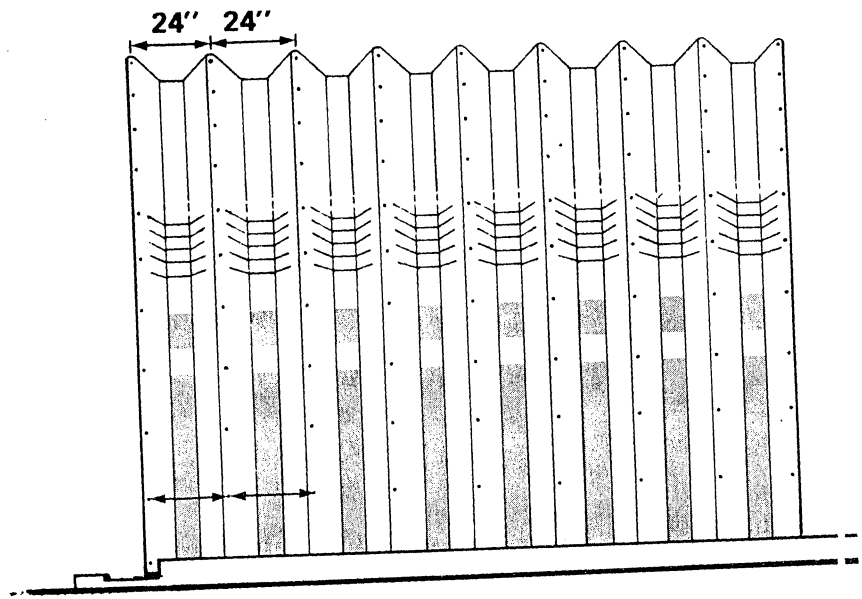

Fig. 26

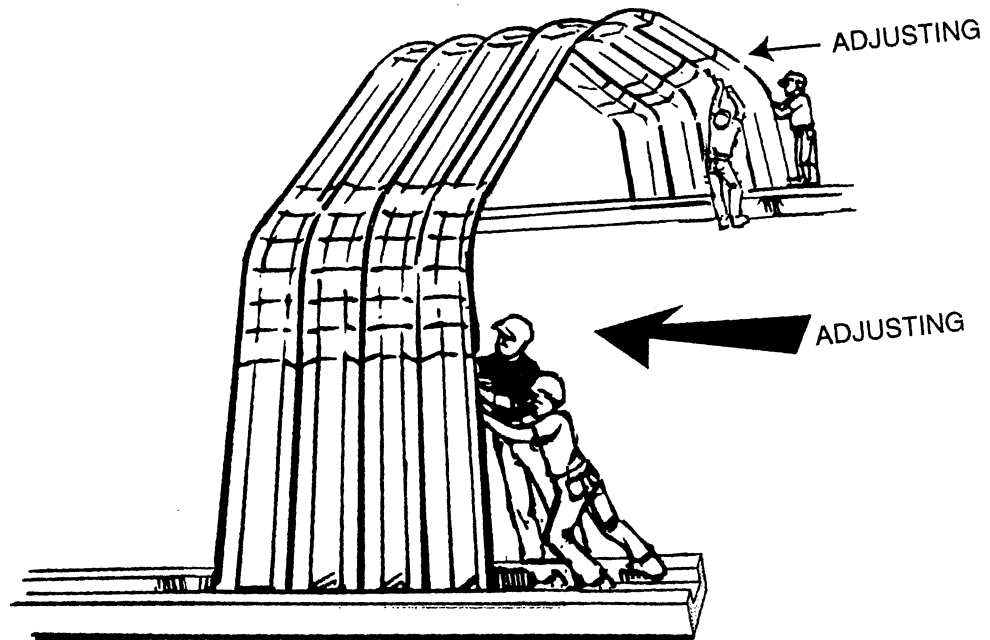

Fig. 27

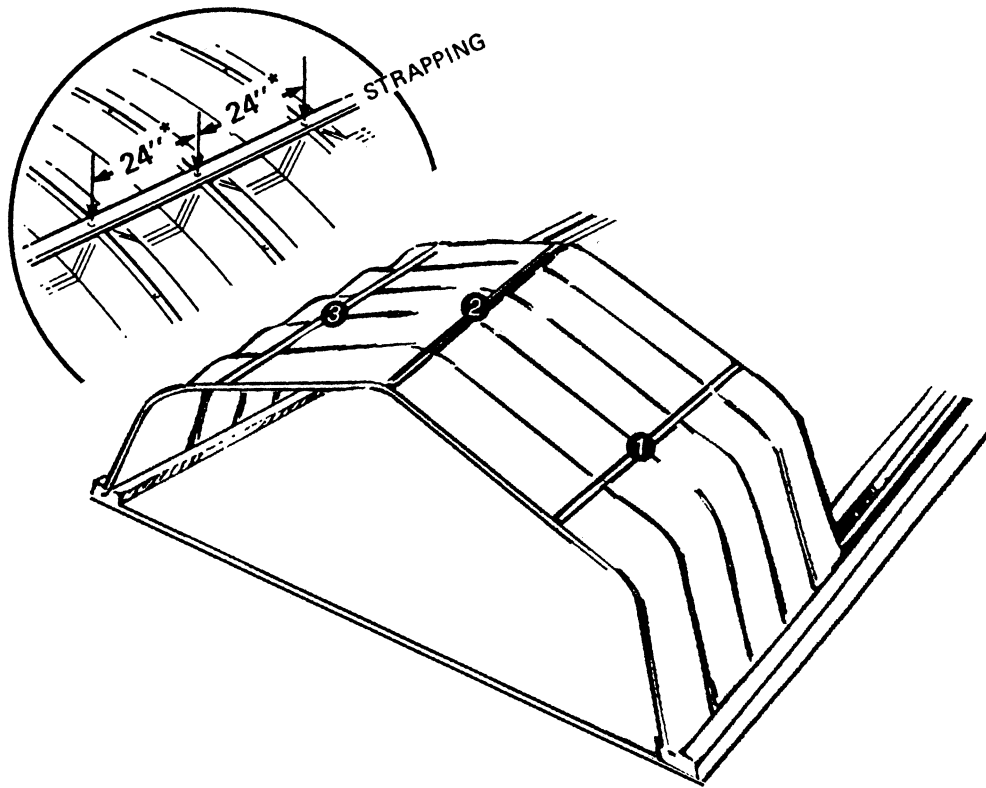

Fig. 28

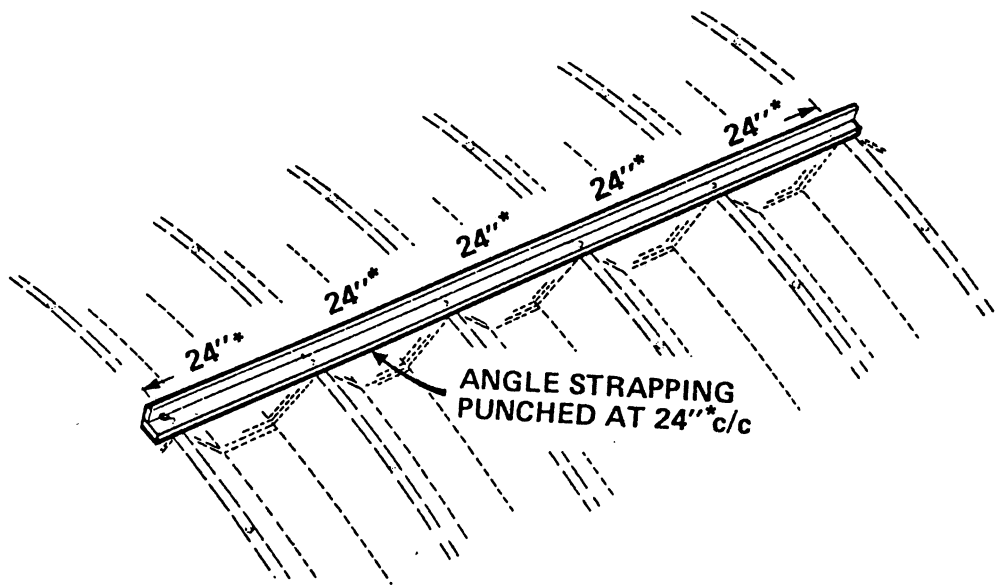

Fig. 29

## HALF ARCH METHOD

There is another method of erecting the arches, which many people find convenient if the arches are very large or if manpower is limited. If you feel the half arch method is more suitable, you may decide to erect your ALPINE building in this manner. You should, however, still read the entire description of the complete arch method, as all directions on caulking (if used) and overlapping of the panels apply to both methods.

When you are ready to begin, check fig. 12 and table 3 for the number of panels in each arch, so that you can lay out the panels on the ground in the right order.

**NOTE:** You should remember to check the proper way of overlapping the panels, as an incorrect overlap is not easily corrected once the arch is up in the air.

Putting up the first arch may be done as follows:

1. Place one or two men on the scaffold, with ropes connected to the first half arch.
2. Have one man at the bottom end of the arch to guide it into the trough, and to lift the end as the arch comes upright, to avoid bending the corners.
3. Have the rest of the crew stationed along the half-arch, to help lift and support it in the air. Provide them with two-by-fours to enable them to push up the arch.
4. Slowly and carefully lift the arch off the ground, lifting the corner clear of the concrete and guiding the end into the trough.
5. Support the top end on the scaffold as shown in Fig. 30, and secure it temporarily by means of ropes or otherwise.
6. Now raise the second half of the arch in the same fashion, guide it into position (see fig. 31) and bolt it to the first half.

**CAUTION:** A single arch, by itself, is very flexible. Under no circumstances should anyone attempt to sit or stand on top of it. See also the remarks on page 33.



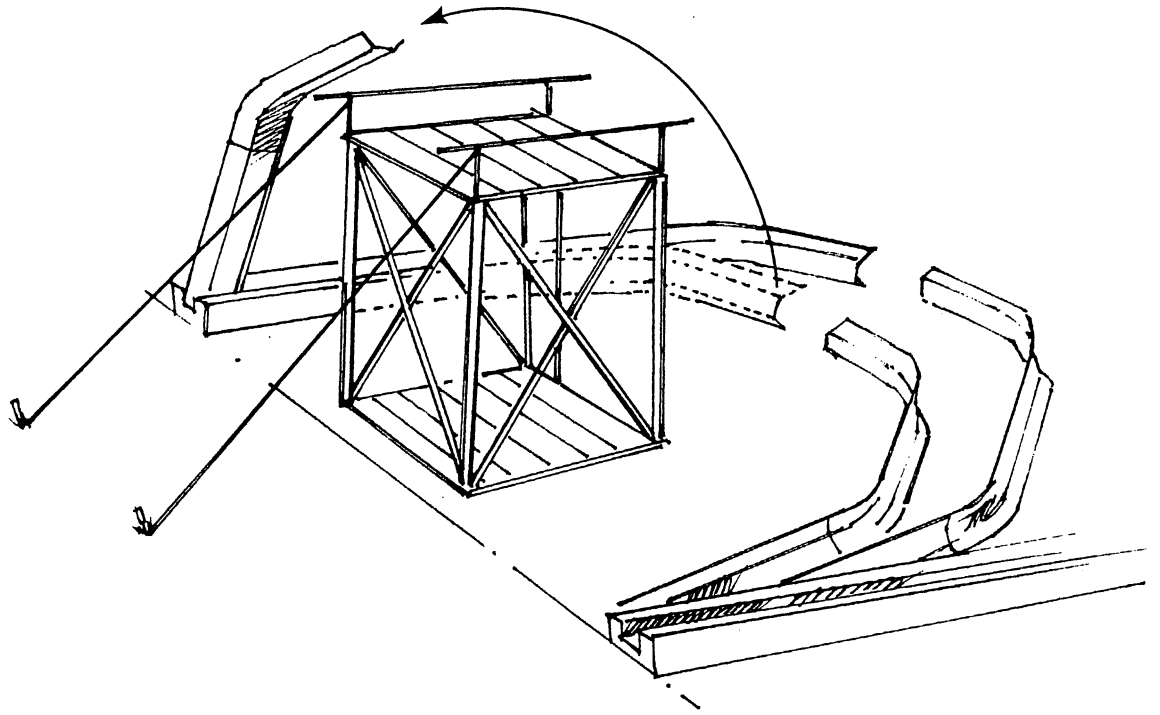

Fig. 30

When the first arch has been completed and properly secured, another half arch can be raised, and bolted to the first arch by inserting every third or fourth bolt. See fig. 29.

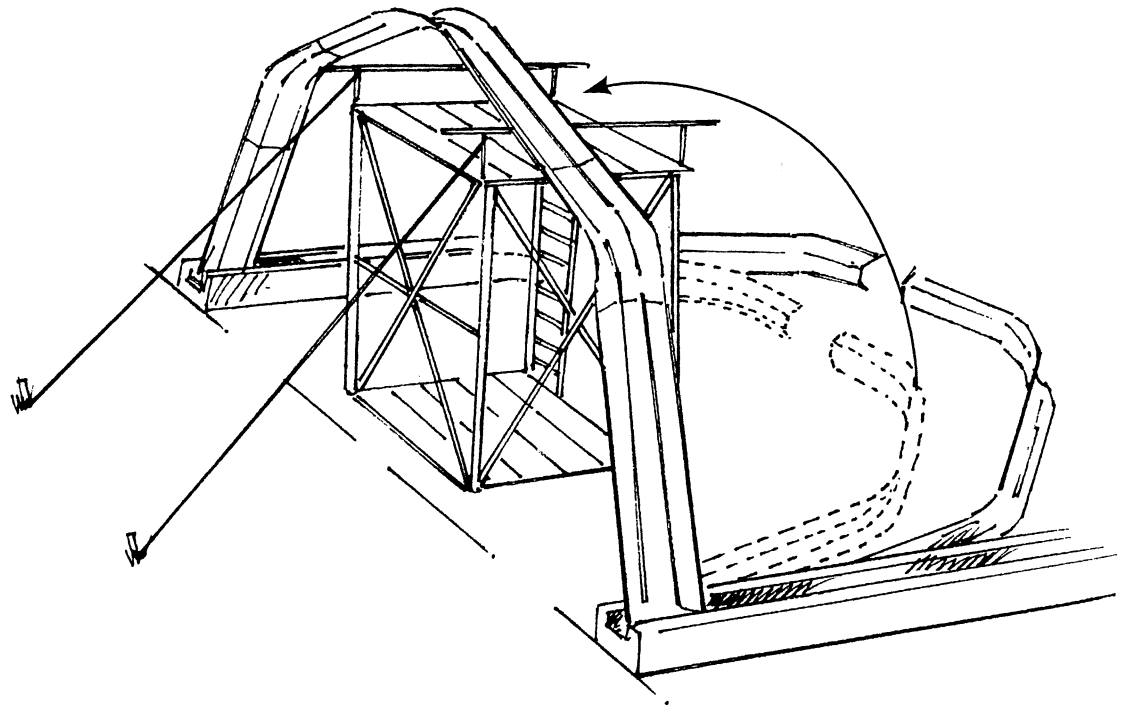

Fig. 31

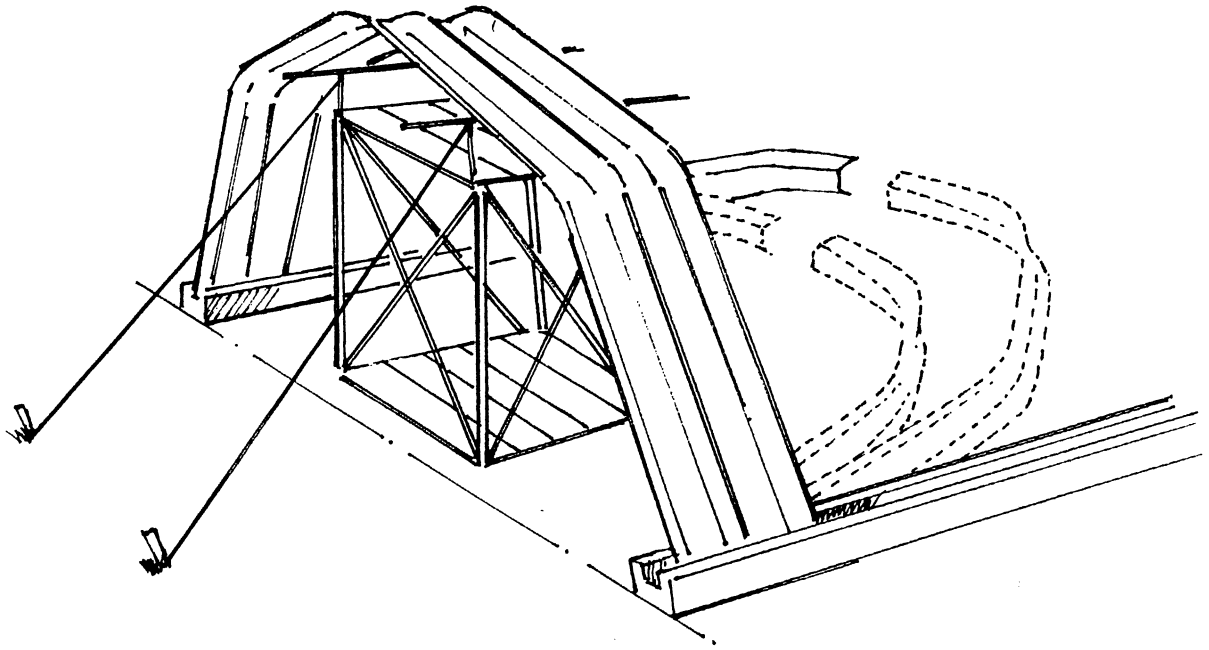

Fig. 32

Now raise the remaining half of the second arch, and bolt it in place. The other arches are added on in the same fashion, half an arch at a time, until all arches have been erected.

At this time, the center point of the arches should be found. This may conveniently be done by counting the bolt holes when the arches are still on the ground, and marking the centers.

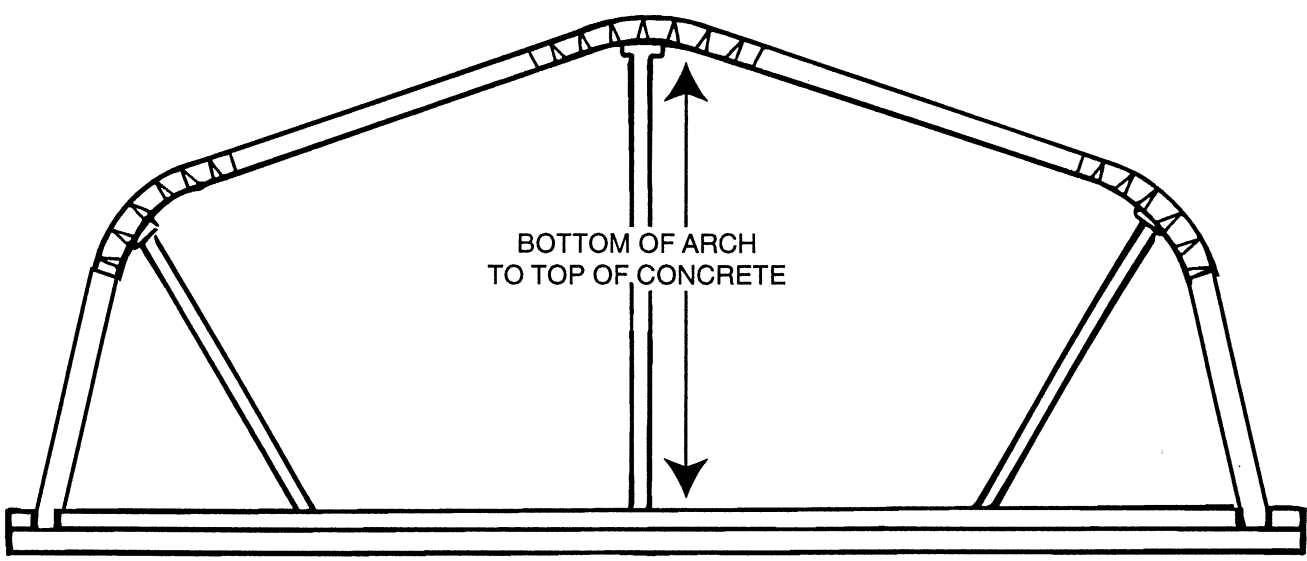

Fig. 33

The center line of the foundation should be found by measuring, and should be clearly marked on the concrete. Now, if a plumb bob is suspended from the center of an arch, the arch can be adjusted so that the plumb bob is directly over the center line on the foundation. If necessary the arch can be propped up with 2 x 6 boards to maintain correct height, as shown for each model in table 4. Bracing the arches in this manner is important for maintaining proper shape of the building, as well as for making the erection of subsequent arches easier. Bracing may be used at intervals of say 10 feet along the length of the building, to maintain the correct dimensions. The arches are extremely flexible, especially before the bolts are tightened, and repeatedly checking dimensions at this stage of the erection may prevent problems later, when the endwalls are being installed (see fig.33).

TABLE 4

BUILDING MODEL:	DIMENSION "A"
A20-12	11'-3"
A25-12	11'-0"
A25-14	13'-1"
A30-14	12'-10"
A30-16	14'-11"
A32-18	17'-2"
A35-14	13'-2"
A35-16	15'-3"
A40-16	15'-0"
A40-18	17'-5"
A45-17	16'-4"
A45-19	18'-4"
A50-17	16'-1"
A50-19	18'-2"

## ERECTION OF THE ENDWALLS

The erection of the endwalls is very important, and extra care should be taken at this stage to ascertain that all dimensions are correct. Read the instructions carefully until all steps are clear in your mind before you attempt the actual installation.

**NOTE:** A certain amount of field-cutting and drilling is sometimes necessary in the installation of the endwalls. Before you cut any pieces, however, make sure that you have read the manual and verified your dimensions!

Before the endwall panels are installed, the large strips of dark-grey foam material (found in the hardware box) should be inserted, end-to-end, into the curved angles, to provide a weather-seal for the profiled tops of the panels.

**NOTE:** It is not necessary to use foam stuffer at the flat panels in the four corners of your ALPINE building, and no foam strips are provided for this purpose. Also, if your particular model has flat panels over the doors you do not require foam strips for those panels, as the flat panels seal to the curved angles. To find out whether your building has flat panels or not, look at table 6 on page 52: if your model has a connector beam, then it does NOT have flat panels.

**NOTE:** Caulking of the vertical endwall panels is NOT required and no caulking is supplied for this purpose.

## ENDWALL WITH SLIDING DOORS

The endwall with the sliding doors should normally be erected first. Checking the door size and laying out the proper dimensions is very important for a good fit of the endwall, and should be done with care. The center line of the concrete should be established and marked as this is the reference point for the other dimensions (see fig.34)

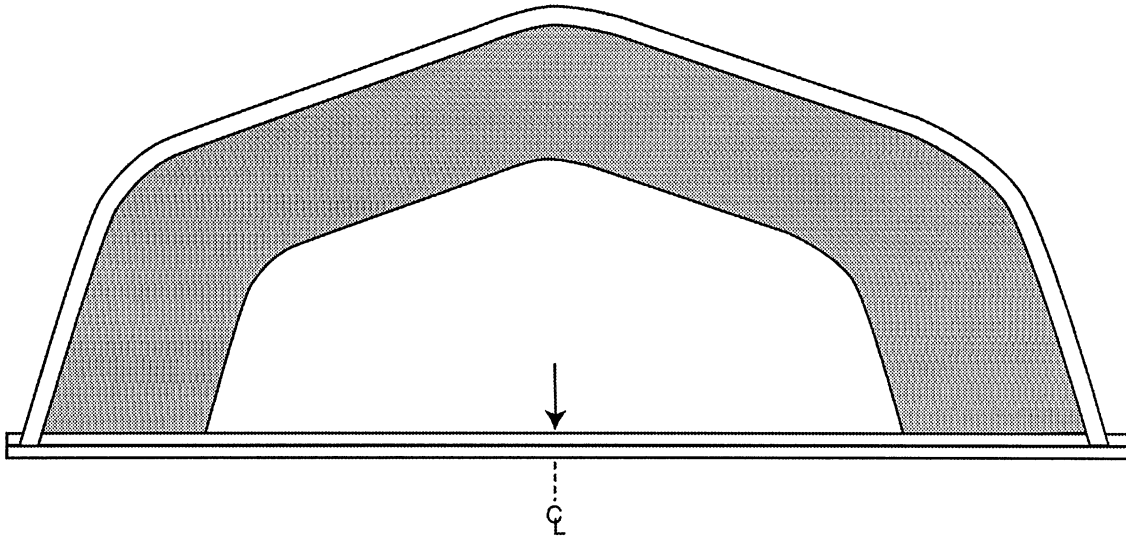

Fig. 34

Starting at the center line, carefully measure the dimensions given in table 5 on the following page, and mark them on the concrete (see fig.35)

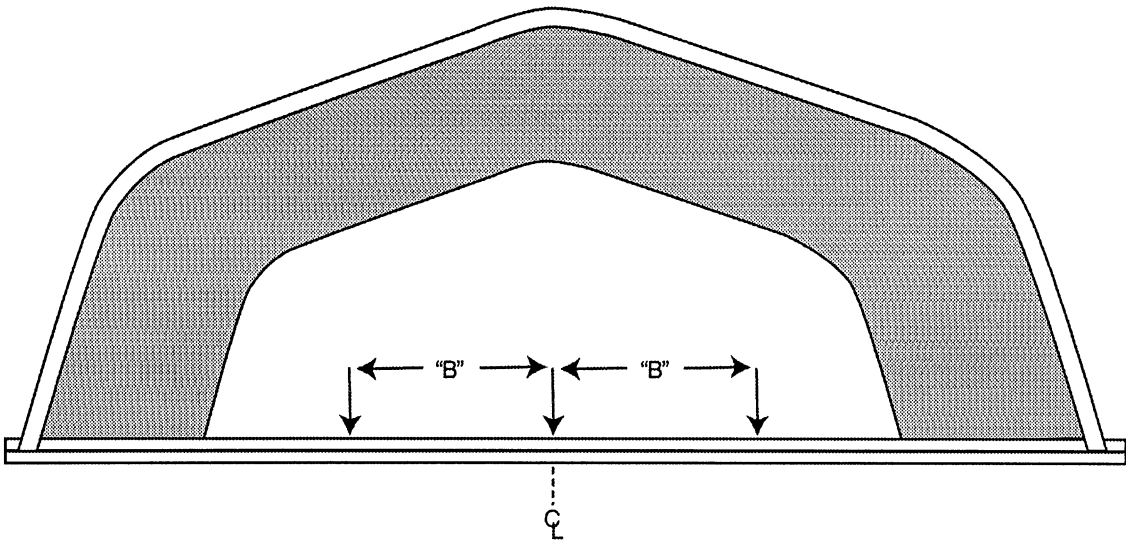

Fig. 35

TABLE 5

DOOR WIDTH (FT.)	DIMENSION "B"
10	5'-0"
11	5'-6"
12	6'-0"
14	7'-0"
16	8'-0"
18	9'-0"
20	10'-0"
22	11'-0"
24	12'-0"

CAUTION: Make certain that you use the correct door size, or else the doorwall panels will not fit. The door size of your particular building is shown in the upper left corner of the packing list. Check to be sure, as the same building model is often supplied with two or three different door sizes.

The endwall panels on both sides of the door opening are now placed in position, and temporarily secured with C-clamps.

NOTE: Dimension "B" is measured from the center line to the edge of the panel.

To make certain that the panels are properly spaced, please use the angle strapping which was previously used on the arches. The angles are used as strapping for the arches and the endwalls; they have prepunched holes to help you space the panels correctly (see fig.36). Install all panels beside the door opening, and insert a few bolts to keep them in place. Do not tighten the bolts at this time, as the endwall may need some adjustment.

When all panels beside the door opening have been installed, the opening must be squared. This is a very important step, as the proper sliding and closing of the doors depends on the accuracy of the door framing. A number of checks should be made:

1. Check dimension "B", both at the bottom and at the top of the door opening, and make certain that it complies with the figures in the table on page 47.
2. Measure the opening diagonally, from corner to corner. The two measurements should be exactly the same.
3. Check both vertical edges of the door opening with a spirit level. Both must be exactly plumb for the doors to slide easily.

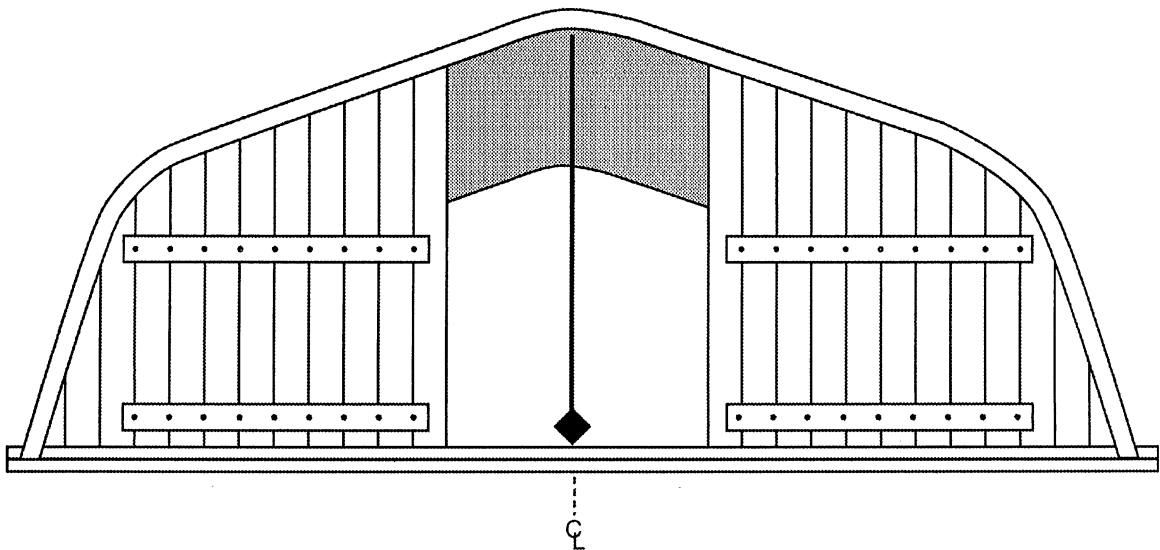

Fig. 36

When the opening has been checked the endwall panels can be secured to the curved angles. This is done by drilling holes through the curved angles and the panels. It is easiest to drill the outer curved angles first, in a vertical line with the existing boltholes in the panels (see fig.37). Bolts should be inserted and tightened before drilling the inner curved angles (one hole for each panel). It is not easy to drill these holes because space is limited, but it is important to properly secure the endwall to the arches, as this contributes to the strength of the endwall.



When the endwall panels have been bolted to the curved angles, the two corner panels can be inserted into the corners of the arch. They are loosely bolted to the last endwall panel to keep them in place, and holes are drilled through the outer curved angles and the corner panels, approximately 9" apart. The easiest way of doing this is having a helper support the panels inside the building, using a piece of lumber, while the drilling is done from the outside. The corner panels are bolted to the curved angles, flush with the angles. It is not necessary to use foam stuffer at this joint, and stuffer is not supplied for this purpose. The bottom ends of the endwall panels are positioned in the foundation trough, and they should be attached to the outer door guides (which have a flat vertical flange), if the outer door guides reach as far as the corners of the building.

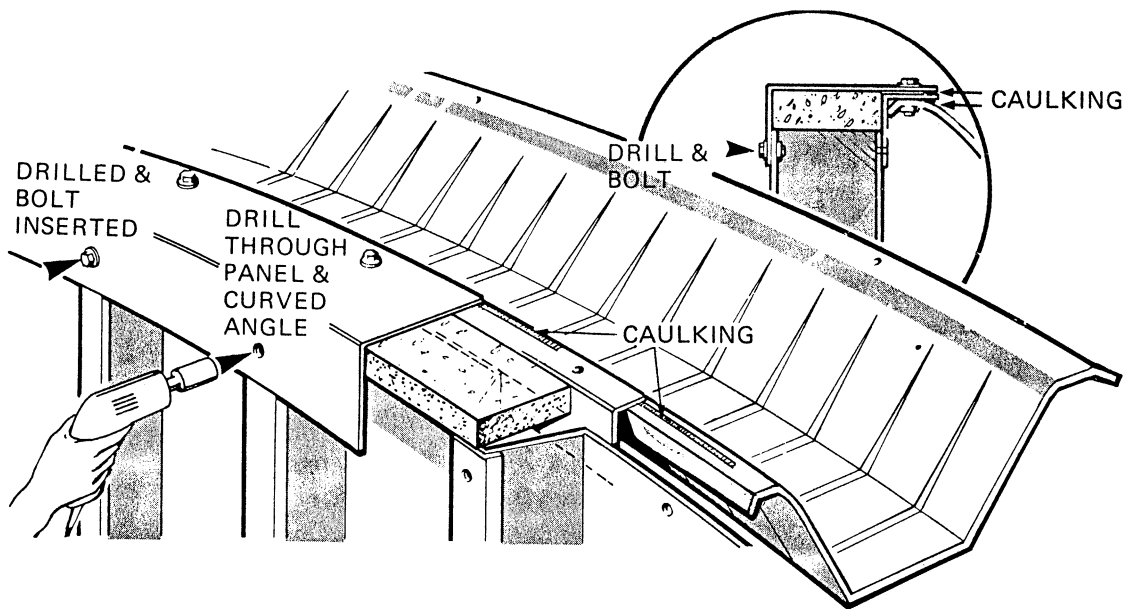

Fig. 37

**NOTE:** Outer door guides are supplied at a length equal to half the width of the door. As an example: if your door is say 24 feet wide you will get two 12-foot inner door guides plus two 12-foot outer door guides. Consequently, if you have a relatively small door in a large building, the outer door guides will not reach the corners of the building, and it is recommended to secure the bottom ends of the cornerpanels with a 2 x 4, until grouting can be done.

When the outer door guides have been bolted to the bottom holes in the endwall panels the door jambs can be loosely bolted (with two or three bolts) onto the panels on either side of the door opening (see fig.38).

NOTE: The top hole in the door jambs should be left unbolted at this time. To determine which end of a doorjamb is the top end, look at the boltholes: the hole in the top end is one half inch from the end of the jamb.

The jamb stiffeners are mounted on the inside of the panel, on either side of the door. Bolts are inserted through the door jamb (still leaving out the top bolt in the jamb), the endwall panel and the jamb stiffener, and after the dimensions of the door opening have been checked once more, all bolts in the endwall can be tightened.

NOTE: The jamb stiffeners are made to fit into the arches of most models. If the arch profile is a little out of line, however, it may be necessary to field-cut the stiffener with a hacksaw. Make sure that the bolthole in the bottom end of the stiffener is 1 1/2" from the end, and cut the top end as required.

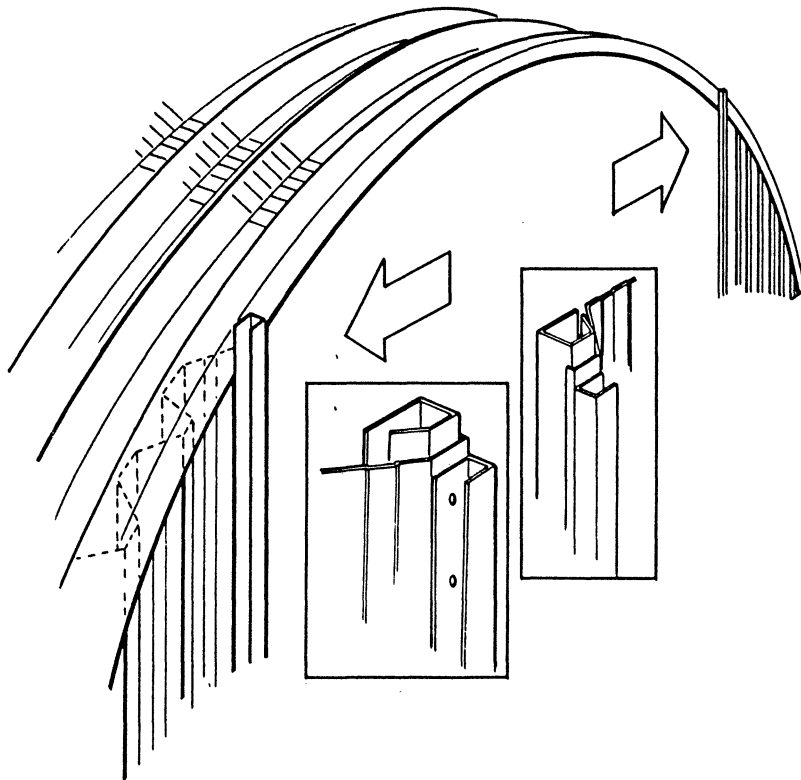

Fig. 38

## DOOR FRAMING

Now that the doorwall is assembled, the door framing must be installed. The door framing procedure varies from model to model, and on some models certain parts are not used at all, so it is important to know exactly which instructions apply to your particular ALPINE building. Check the top left corner of the packing list which you receive with the shipment for model number and nominal door size; then check table 6 on the following page. The table will show you whether your building uses a connector beam or not. If it does, you should follow the instructions given on page 53. If it does not have a connector beam, however, follow the instructions on page 56.

Read the following pages carefully until you understand how the door framing is assembled. Experience has shown that mistakes are sometimes made at this stage, and those mistakes could be hard to correct later on.

**NOTE:** If your building has a non-standard door, i.e. a door not listed in the table for your model, ask your dealer for assistance or phone the Engineering Department at the factory.

**NOTE:** We manufacture more than forty different models, some with two or three different door sizes. This manual cannot possibly show every little detail of every door, but it takes you through the general procedure to be followed.

Most buildings have a connector beam mounted over the door, but on some models with a lower profile and a high door a connector beam cannot be used. Check this table to see whether your model has connector beams or not, as this affects the assembly procedure.

TABLE 6

MODEL	DOOR SIZE	CONNECTOR BEAM USED	MODEL	DOOR SIZE	CONNECTOR BEAM USED
A20-12	8 X 10	YES	A40-16	14 X 16	NO
A20-12	9.5 X 12	NO	A40-16	14 X 18	NO
A25-12	8 X 10	YES	A40-16	14 X 18	NO
A25-12	9.5 X 12	NO	A40-18	11 X 14	YES
A25-14	8 X 10	YES	A40-18	11 X 16	YES
A25-14	9.5 X 12	YES	A40-18	12.5 X 16	YES
A25-14	9.5 X 14	YES	A40-18	12.5 X 18	YES
A25-14	11 X 14	NO	A40-18	14 X 16	YES
A30-14	9.5 X 12	YES	A40-18	14 X 18	YES
A30-14	11 X 14	NO	A40-18	14 X 20	YES
A30-14	11 X 16	NO	A45-17	11 X 16	YES
A30-14	12.5 X 16	NO	A45-17	12.5 X 18	YES
A30-16	11 X 12	YES	A45-17	14 X 14	YES
A30-16	11 X 14	YES	A45-17	14 X 16	YES
A30-16	12.5 X 14	YES	A45-17	14 X 18	YES
A30-16	12.5 X 16	YES	A45-17	14 X 20	YES
A30-16	14 X 14	NO	A45-17	14 X 22	YES
A30-16	14 X 16	NO	A45-17	14 X 24	YES
A32-18	11 X 12	YES	A45-19	11 X 16	YES
A32-18	11 X 14	YES	A45-19	12.5 X 18	YES
A32-18	12.5 X 14	YES	A45-19	14 X 14	YES
A32-18	12.5 X 16	YES	A45-19	14 X 16	YES
A32-18	14 X 14	YES	A45-19	14 X 18	YES
A32-18	14 X 16	YES	A45-19	14 X 20	YES
A35-14	11 X 14	YES	A45-19	14 X 22	YES
A35-14	11 X 16	YES	A45-19	14 X 24	YES
A35-14	12.5 X 12	NO	A50-17	12.5 X 18	YES
A35-14	12.5 X 16	NO	A50-17	14 X 18	NO
A35-16	11 X 14	YES	A50-17	14 X 20	NO
A35-16	12.5 X 14	YES	A50-17	14 X 22	NO
A35-16	12.5 X 16	YES	A50-17	14 X 24	NO
A35-16	14 X 16	NO	A50-19	12.5 X 18	YES
A35-16	14 X 18	NO	A50-19	14 X 20	YES
A40-16	11 X 14	YES	A50-19	14 X 22	YES
A40-16	11 X 16	YES	A50-19	14 X 24	YES
A40-16	12.5 X 12	YES	A50-19	15.5 X 22	YES
A40-16	12.5 X 16	YES	A50-19	15.5 X 24	YES
			A50-19	15.5 X 26	YES

## DOORWALL WITH CONNECTOR BEAM

NOTE: These instructions apply ONLY to models having a connector beam (see page 52). For doorwalls WITHOUT a connector beam, please turn to page 56.

First, find the two sections of the connector beam (usually shipped strapped together as a separate bundle) and bolt them firmly together.

NOTE: On smaller doors the connector is made in one piece check your packing list to make sure.

The assembled connector beam is then moved inside the building and raised up to the right level (see table 7). It should be temporarily secured, by means of C-clamps, to the curved angles or to the attachment plates. A wooden brace should be used to support the beam in the center, so that it can be leveled. The mounting height of the connector beam is critically important for proper sliding of the doors. Dimension "C" in table 7 is measured from the BOTTOM of the concrete trough to the BOTTOM of the connector beam (see fig.39)

TABLE 7

DOOR HEIGHT (FT.)	DIMENSION "C"
8	8'-4"
9.5	9'-10"
11	11'-4"
12.5	12'-10"
14	14'-4"
15.5	15'-10"

In models having a connector beam the panels mounted over the door are short profiled panels, looking like the panels which have been previously installed beside the door opening. The overdoor panels are slipped in place above the connector beam, starting at the center of the building. The top ends of the panels are inserted between the inner and outer curved angles, and the bottom ends are then lifted into position on the connector beam, and loosely bolted to the beam (see fig.40).

The last panel to go in on either side is a flat panel, called the "overdoor corner panel" (which is triangular in shape) or the "overdoor adapter panel" (which has one curved and three straight sides). You will usually find them printed on page 2 of your packing list, and packed in the hardware box.

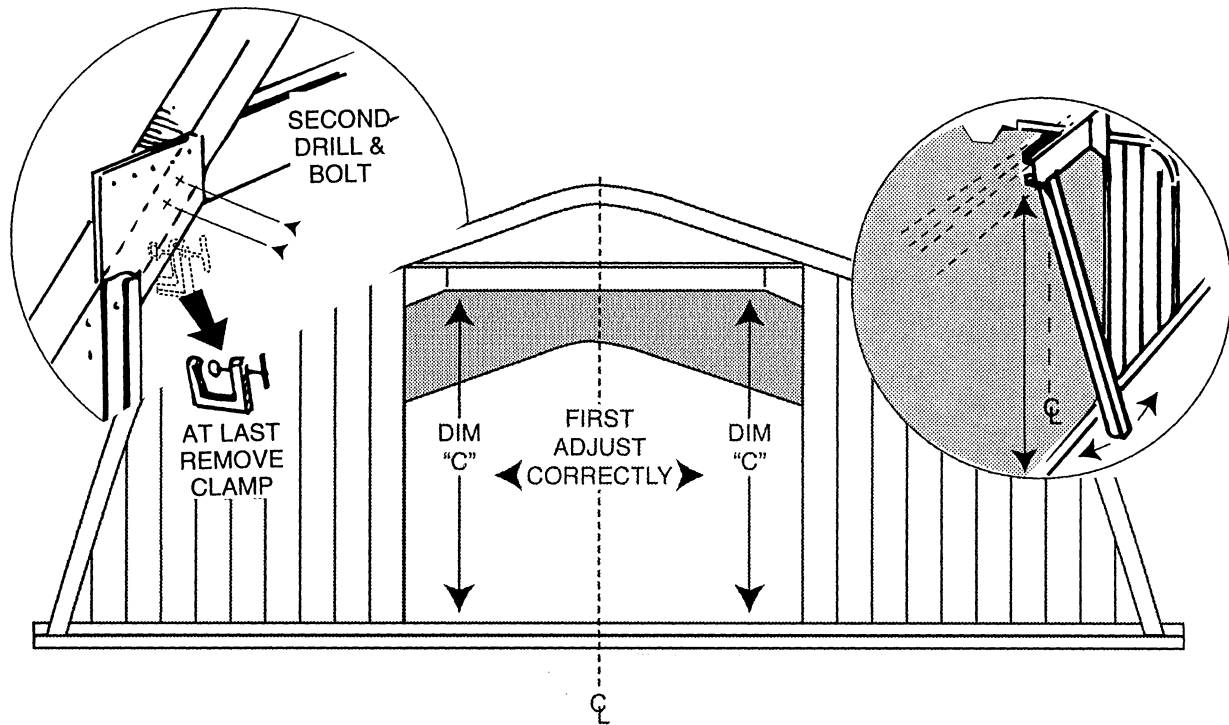

Fig. 39

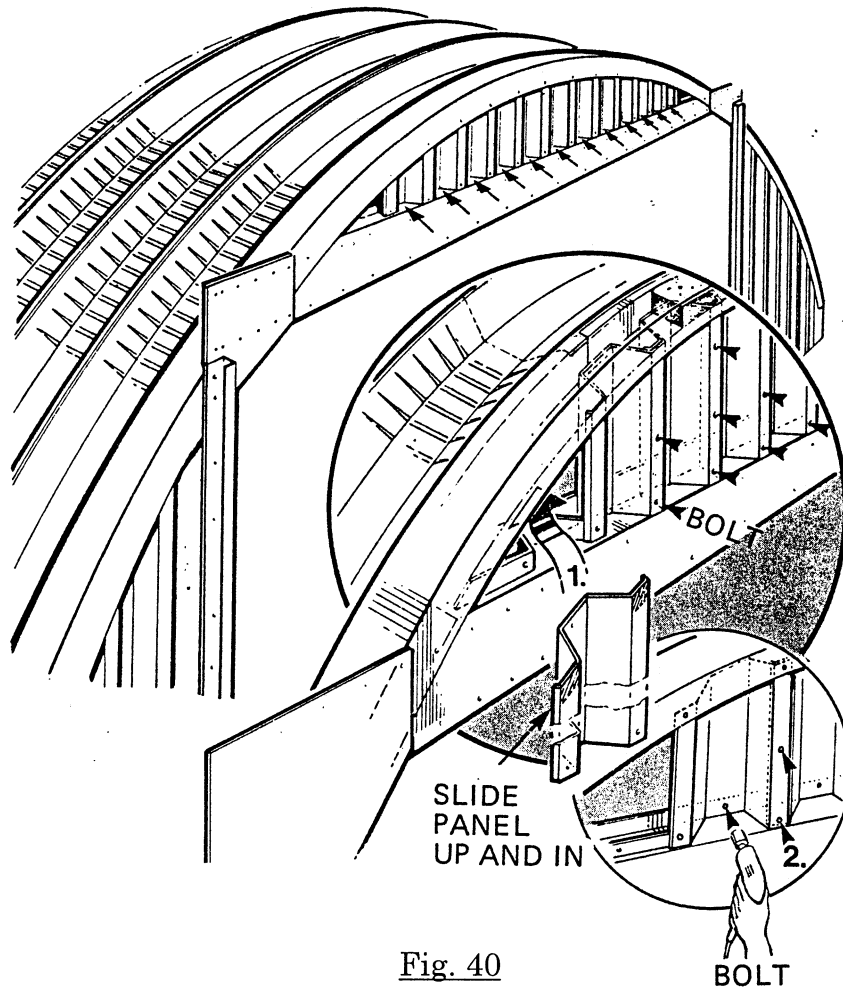

Fig. 40

BOLT

The connector beam may sag slightly in the middle, due to its own weight and the weight of the overdoor panels. It should be propped up in the center, using a wooden brace, until it is straight and level.

When the connector beam is accurately positioned, the overdoor panels must be drilled and bolted to the inner and outer curved angles, exactly as was done with the panels beside the door (see fig.41).

At this time it is practical to mount the attachment plates at the top corners of the doorway. The attachment plates are fairly thick triangular plates, intended to connect the door jambs to the connector beam and/or the header beam. Install them at the top of the door jambs as shown in fig.41, again leaving all bolts loose.

## DOORWALL WITHOUT CONNECTOR BEAM

NOTE: These instructions apply ONLY to models not having a connector beam (see page 52). For doorwalls WITH a connector beam, please ignore these instructions and return to page 52.

If a connector beam is not used, it becomes even more important to ensure that the header beam is straight and level. Assemble and erect the header beam as described on pages 57 and 58, and secure it in place by clamping or other suitable means. The header beam, like all other beams, will tend to sag in the middle due to its own weight. To correct this, it should be supported where necessary, using wooden braces. The mounting height of the header beam is critically important for proper sliding of the doors. Dimension "C" in table 8 is measured from the BOTTOM of the concrete trough to the BOTTOM edge of the header beam flange.

TABLE 8

DOOR HEIGHT (FT.)	DIMENSION "C"
8	8'-4"
9.5	9'-10"
11	11'-4"
12.5	12'-10"
14	14'-4"
15.5	15'-10"

When the header beam is straight and at the correct height, the two large triangular flat overdoor panels should be hoisted behind the header beam, and bolted to both header beam flanges. When these panels are in place holes should be drilled through the curved angles and the flat panels at about 9" centers, and the panels should be bolted up.

NOTE: It is not necessary to use foam stuffer behind the flat panels, and no foam stuffer is included for this purpose.



## HEADER BEAM ASSEMBLY

The header beam consists of separate sections bolted together using splicer plates. On small ALPINE buildings only two sections are required, whereas up to five sections may be used on the larger models. Check your packing list for the number of header beam sections in your particular model. It is recommended to assemble the header beam sections on the ground. The splicer plates are placed on the front face, and loosely bolted. When the header beam assembly is perfectly straight, the bolts are securely tightened. Next, the track brackets are bolted to the header beam, using the bolt holes in the front face of the beam. Many of the beam sections have hole patterns to suit several models, and some of the holes may not be used on your model. As a rule the track brackets are installed roughly two feet apart, using all the brackets supplied in the hardware box. The assembly may be raised to the top of the door opening using scaffolding on either side of the doorway. Some people prefer to bolt the vertical posts to the header beam assembly first, and then raise the structure by placing the bottom ends of the vertical posts in the endwall trough, and hoisting up the beam by using ropes from the top of the building, supporting the ends of the beam from the ground at the same time. This procedure is somewhat similar to raising the arches, and it is the recommended method, providing you have enough manpower and equipment. As an alternative, the assembled header beam can be raised by itself, and supported in place while the bolts are inserted. It is also possible to raise the header beam section by section, securing each section until the beam is complete. See fig.42.

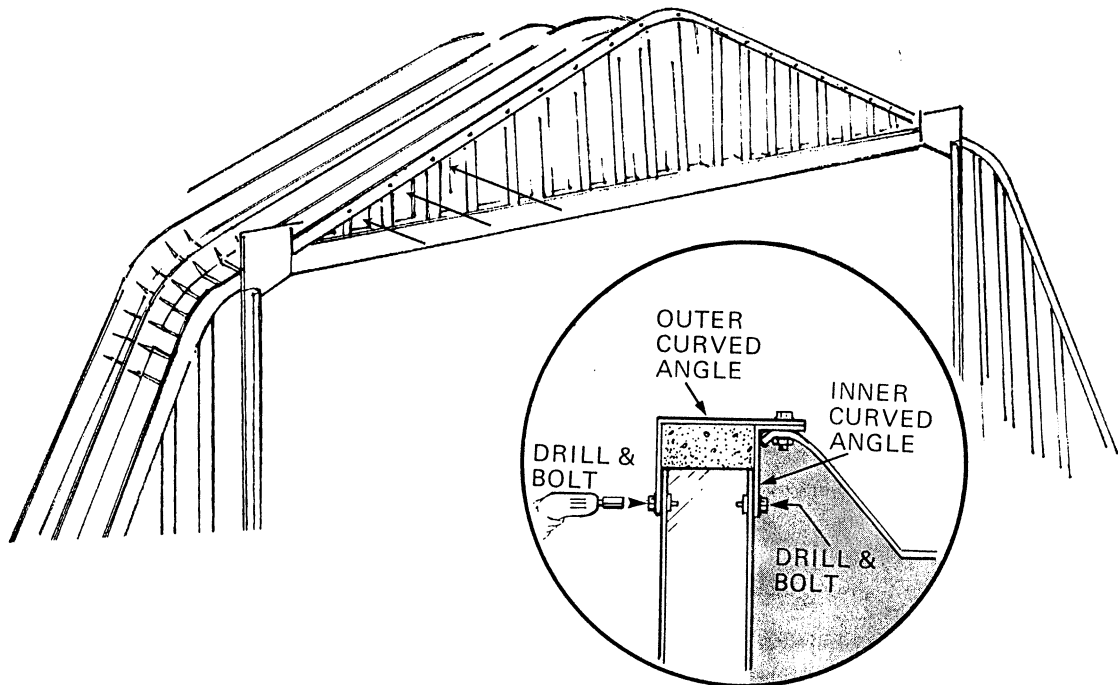

Fig. 41

When the header beam is in position over the door opening it should be lifted up another inch so that the bottom flange can be slipped in behind the tops of the door jambs. As soon as that has been done, insert as many bolts as possible, connecting the beam to the attachment plates and the connector beam, if used. It will be necessary to loosen the bolts in the splicer plates, so that they, too, can be inserted into the components behind the beam. This should be done carefully, a few bolts at a time.

NOTE: It is a good idea to put a strip of caulking, if used, along the header beam top flange. This will prevent possible corrosion due to water seepage into this joint.

As soon as the header beam is bolted on it should be checked for being straight and level. If everything is in order all bolts joining the header beam to the connector beam (if used) should be tightened. Checking the dimensions is important: the header beam should not only be perfectly straight but level as well, to ensure that the doors will open smoothly. The vertical posts should be plumb, but the bolts should not be tightened, as the posts must be removed when the doors are hung.

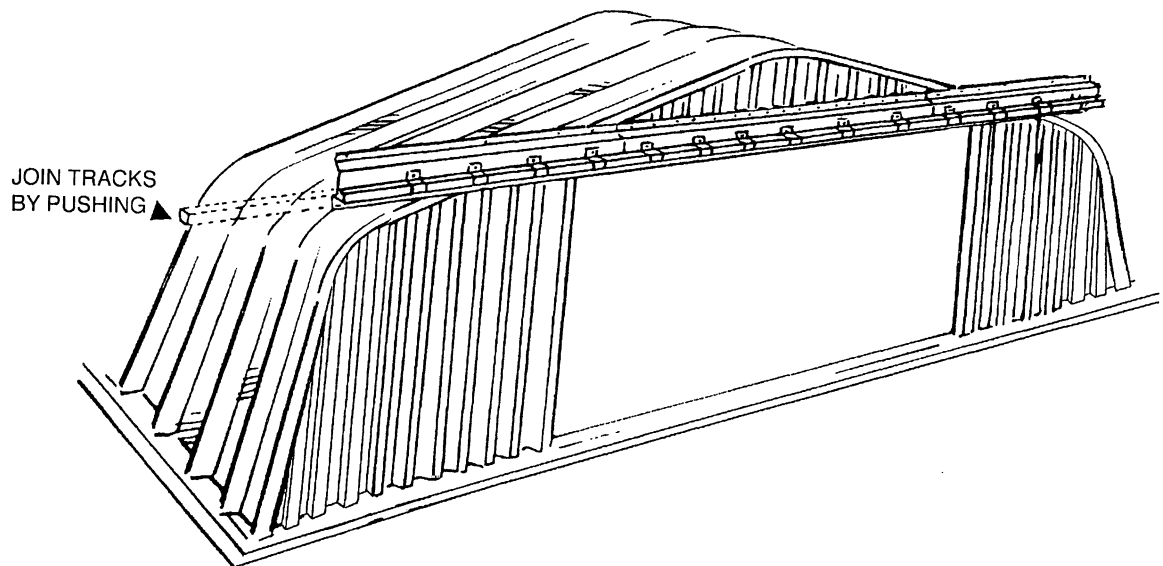

Fig. 42

When the header beam is securely bolted, the door tracks can be installed in the track brackets by pushing them into the brackets at the ends of the header beam, and sliding them along until they meet. Normally, they will join at a track bracket, so that they can be fastened to each other by means of a joiner clip (found in the hardware box). See fig.43 for details.

NOTE: On one or two small models the door track must be cut to length with a hacksaw. The cut ends should be positioned at the outside ends of the header beam.

If your ALPINE building uses a connector beam, the beam should be braced inside the building by installing a wind brace provided for this purpose. The brace is a piece of pipe 60 or 120 inches long (depending on door height) with flattened ends in which holes have been punched. Bolt the brace inside the bottom of the connector beam, and bolt the other end to the arches, after drilling a hole in the arch. It is good practice to apply some caulking around the hole to prevent leaks.

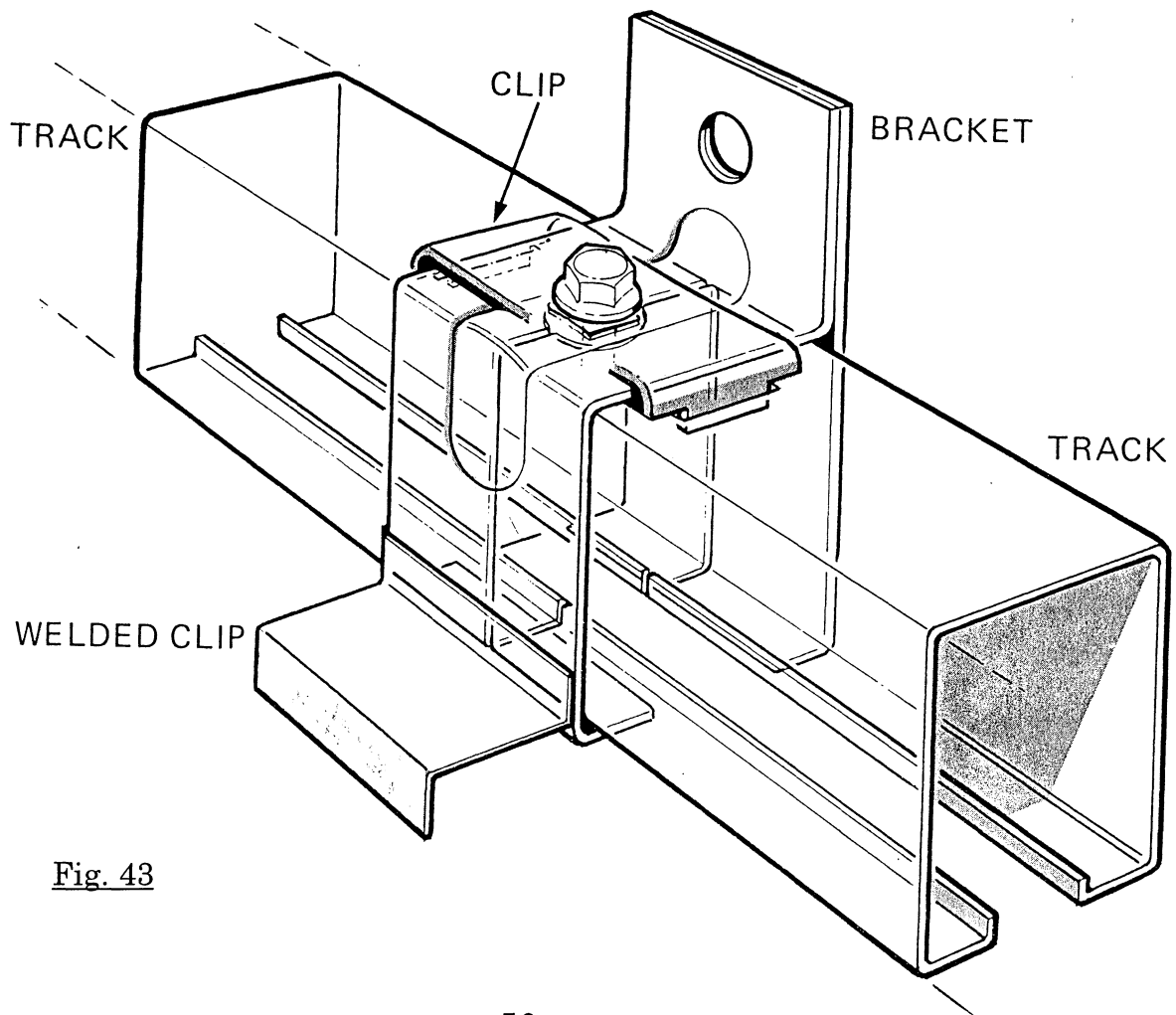

Fig. 43

The vertical posts, which support the ends of the header beam, can now be placed in position. Their location depends on the width of the building and the width of the door. If the door is small, the posts must be located in front of the end wall, but for a very large door the posts will end up beside the building, sometimes a few feet away from it. Fig.44 shows the post at the corner of the building; this only occurs when the door is half the width of the building. The header beam can be bolted on in two different ways, as shown in fig.44. The way shown in the lower circle has the advantage that the posts do not have to be removed again to hang the doors.

**NOTE:** If the posts are located in front of the doorwall, then they **MUST** be installed as shown in the upper circle. This is always the case when the width of your door is less than half the width of the building.

If the posts cannot be placed on the building foundation (in case of relatively large doors) they should be temporarily supported, for instance on a concrete block. Later, when you are grouting, you can build a small form and pour concrete to secure the posts in place.

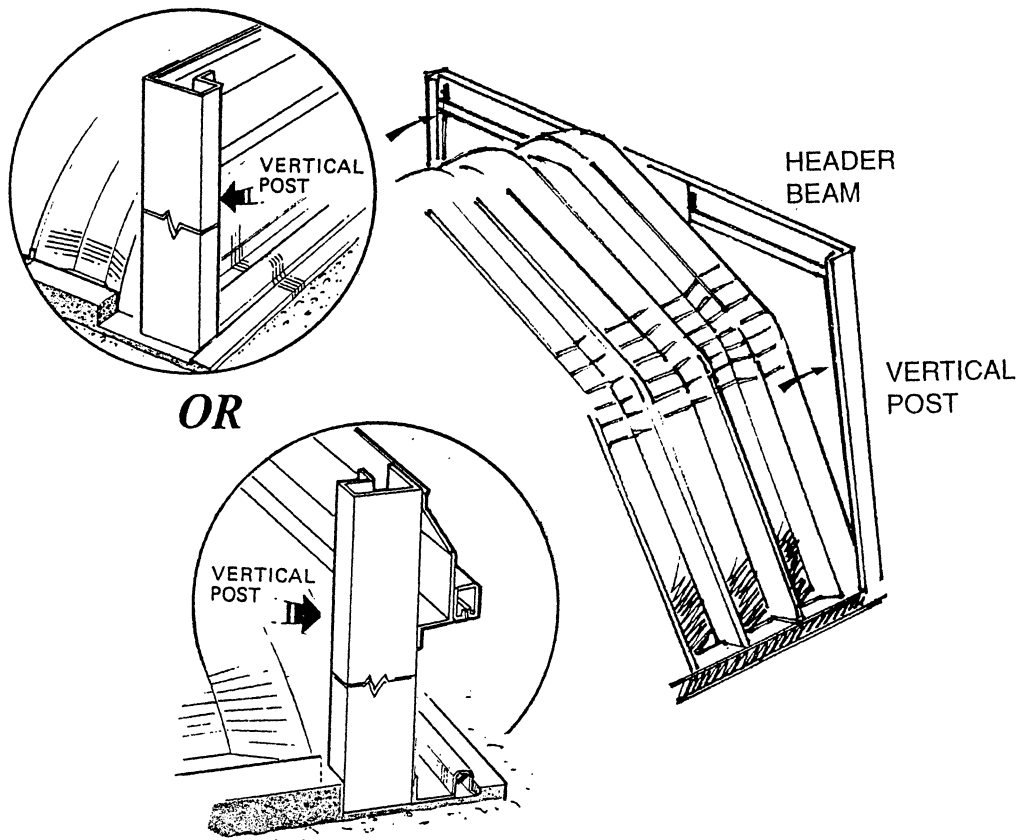

Fig. 44

The header beam assembly must be braced to the outside of the building. This step should not be overlooked, as the doors can catch the wind when they are wide open, and damage to the header beam could result if it is not securely braced. Long (120") and/or short (60") pieces of pipe with flattened ends are used for this purpose; the quantity depends on building size and on the door size. Check your packing list for the number of windbraces shipped with your building. The windbraces must be bolted from the arches to the bottom of the header beam (see fig.45). For maximum effect, they should be installed as nearly horizontally as possible. It is recommended to install the windbraces before the doors are hung.

This completes the installation of the door endwall. If your ALPINE building has two doorwalls, simply repeat the procedure for the other end; if the second wall is solid, refer to page 71.

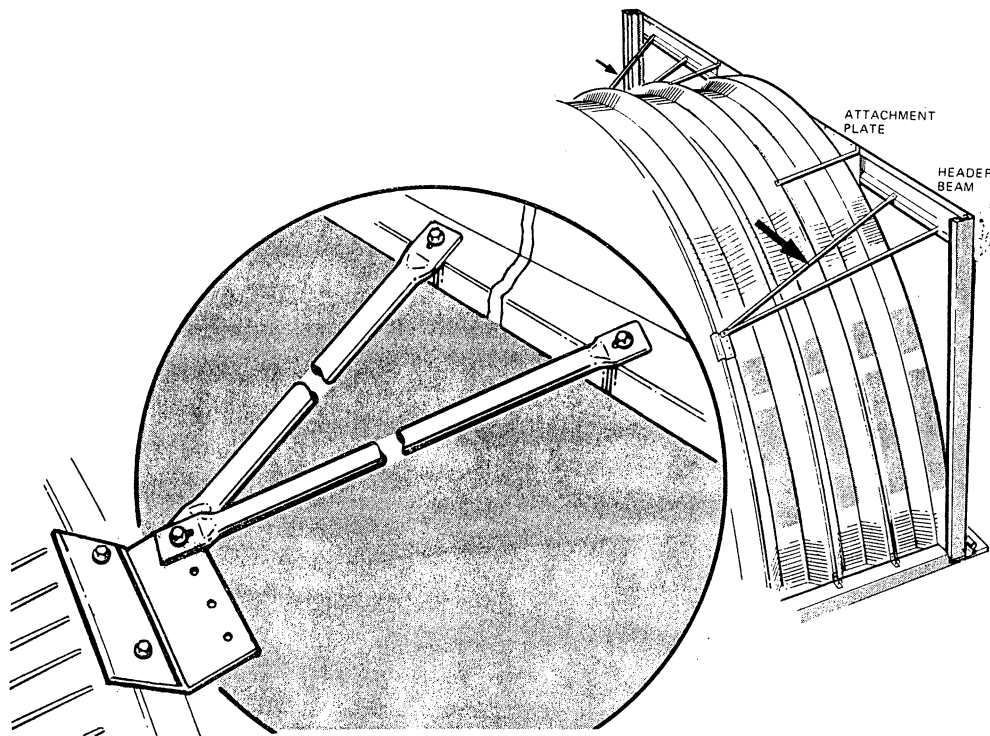

Fig. 45

## SLIDING DOOR ASSEMBLY

The standard sliding door for your ALPINE building consists of a left and a right section, the assembly of which is very similar. It is recommended to assemble these doors in a horizontal position, raised approximately three feet off the ground, so that someone can work under the door during assembly. Wooden sawhorses are suitable for this purpose.

**NOTE:** If your ALPINE building has been ordered with special doors, such as over-sized or off-center doors, the following instructions may not apply. In case of doubt, check with your dealer.

Assembly is begun on the ground. Locate the top door channel (it has some small holes in the top) and the stiffener bars. The stiffener bars are flat strips of steel with a nut welded to their centers, and they are packed in the hardware box. Bolt them to the inside of the top door channel, as shown in fig.46.

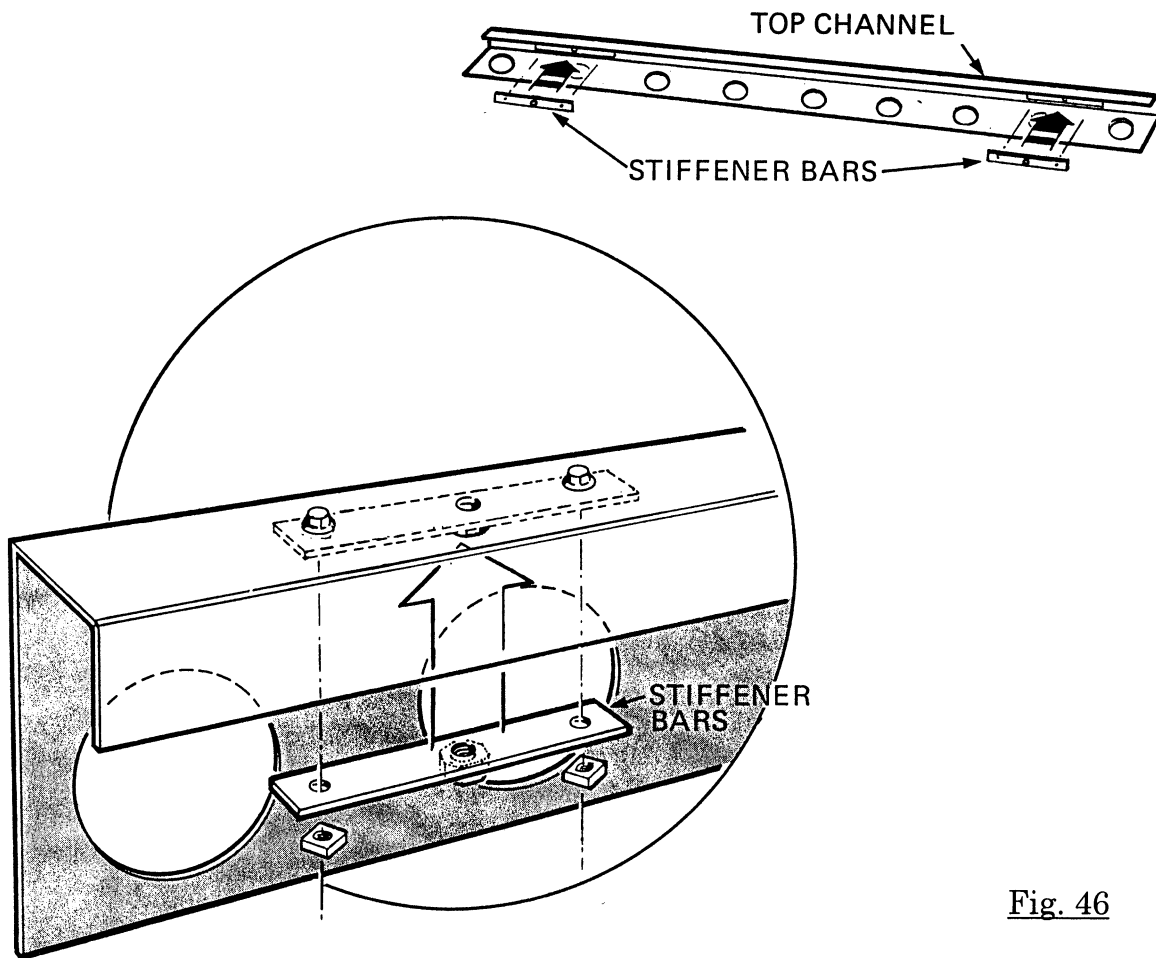
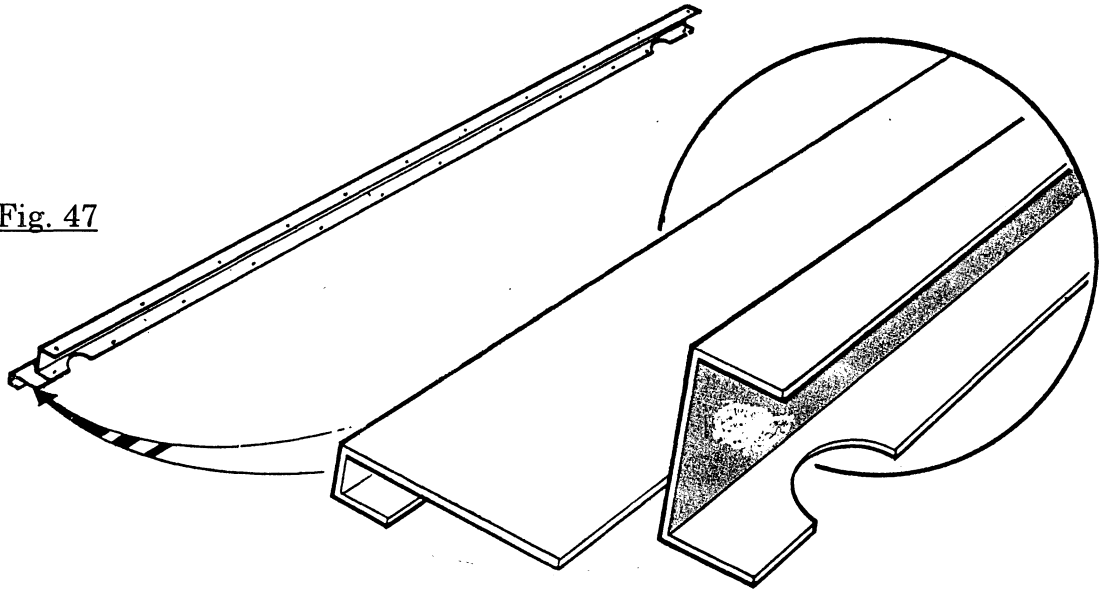

Fig. 46

The vertical door channels are readied for assembly by bolting the door seals or closures onto them. The door seals are formed strips of steel intended to seal the doors in the center and at the sides, to keep out snow, rodents or birds.

Fig. 47



NOTE: It is best to bolt the side door closure seal once the door is completely assembled.

A side door seal must be bolted onto one vertical door channel for each door (see fig.47), whereas the center door seal is attached to one of the vertical channels by means of self-drilling screws, found in the hardware box (see fig.48).

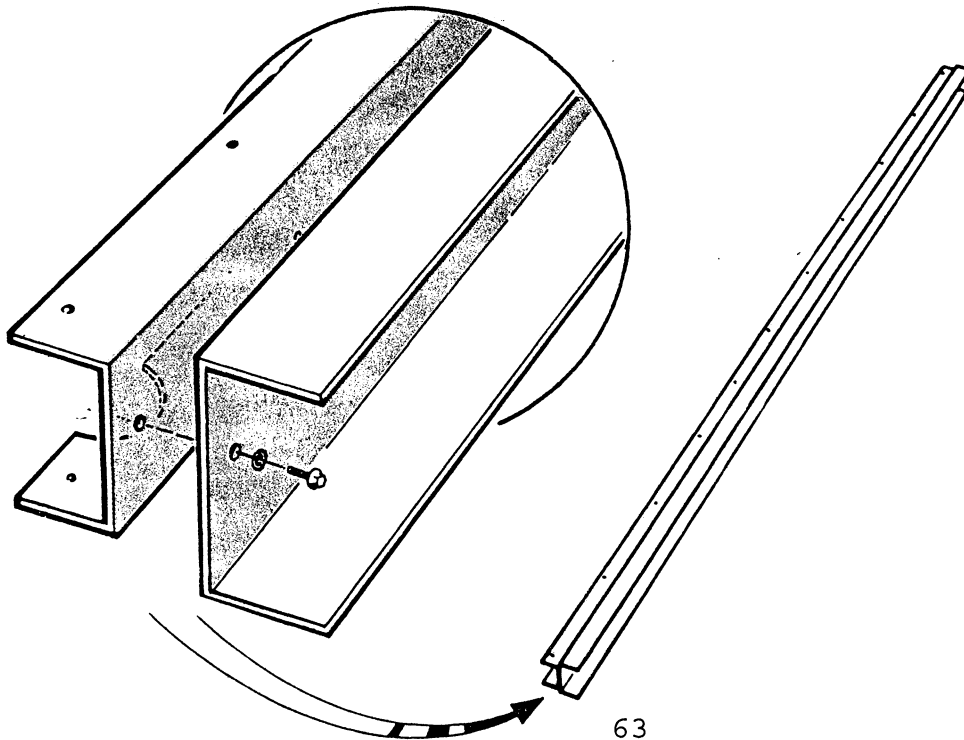

Fig. 48

Locate the door rollers in the hardware box, and thread them into the top door channel by engaging their threaded stems with the nuts of the stiffener bars (see fig.49). The top door channel may now be bolted to two vertical channels, leaving the bolts loose, and this frame should be carefully raised off the ground and placed on the sawhorses or other supports. It is then quite easy to slide the door panels into this frame from the bottom end (see fig.50).

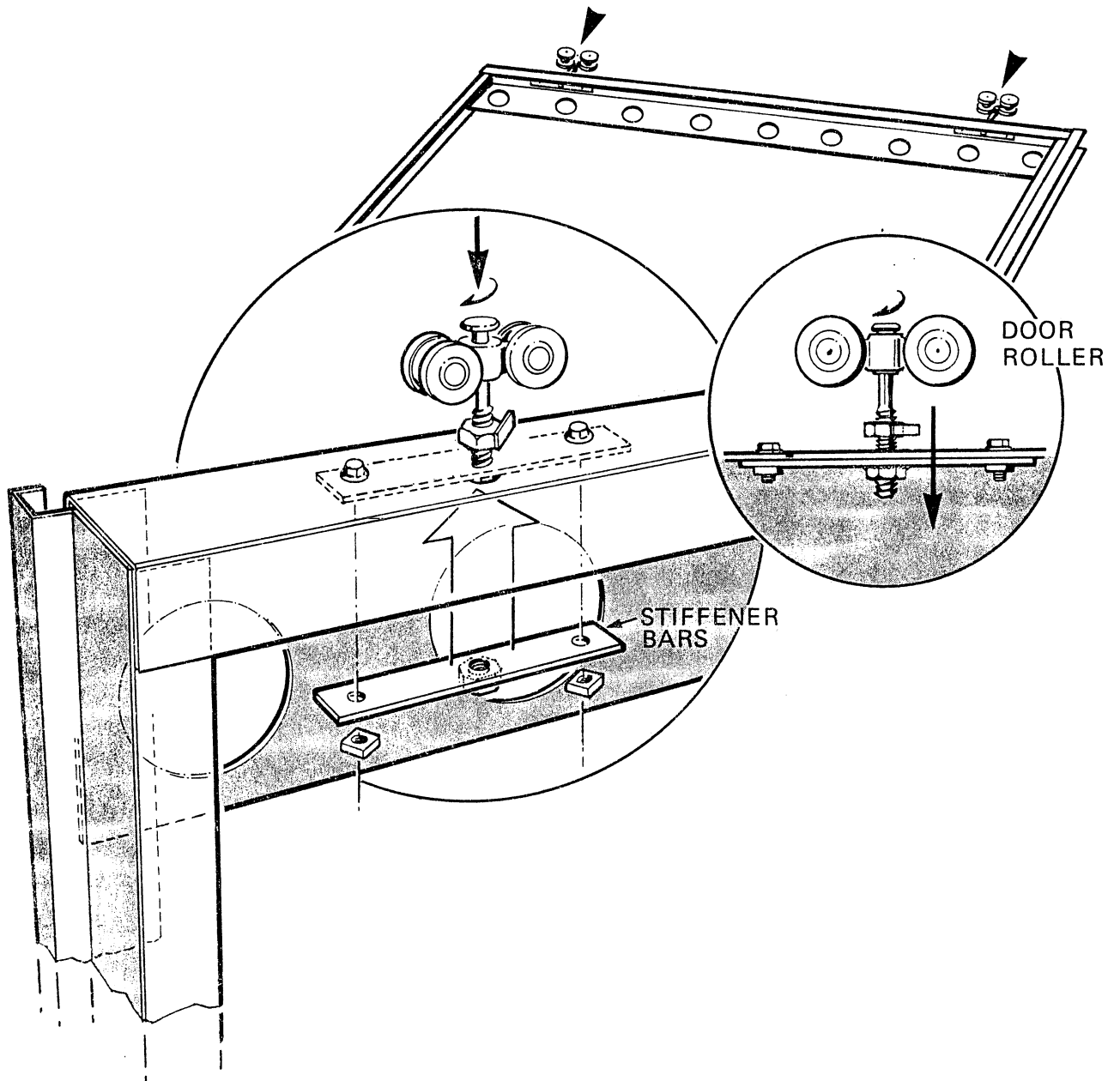

Fig. 49



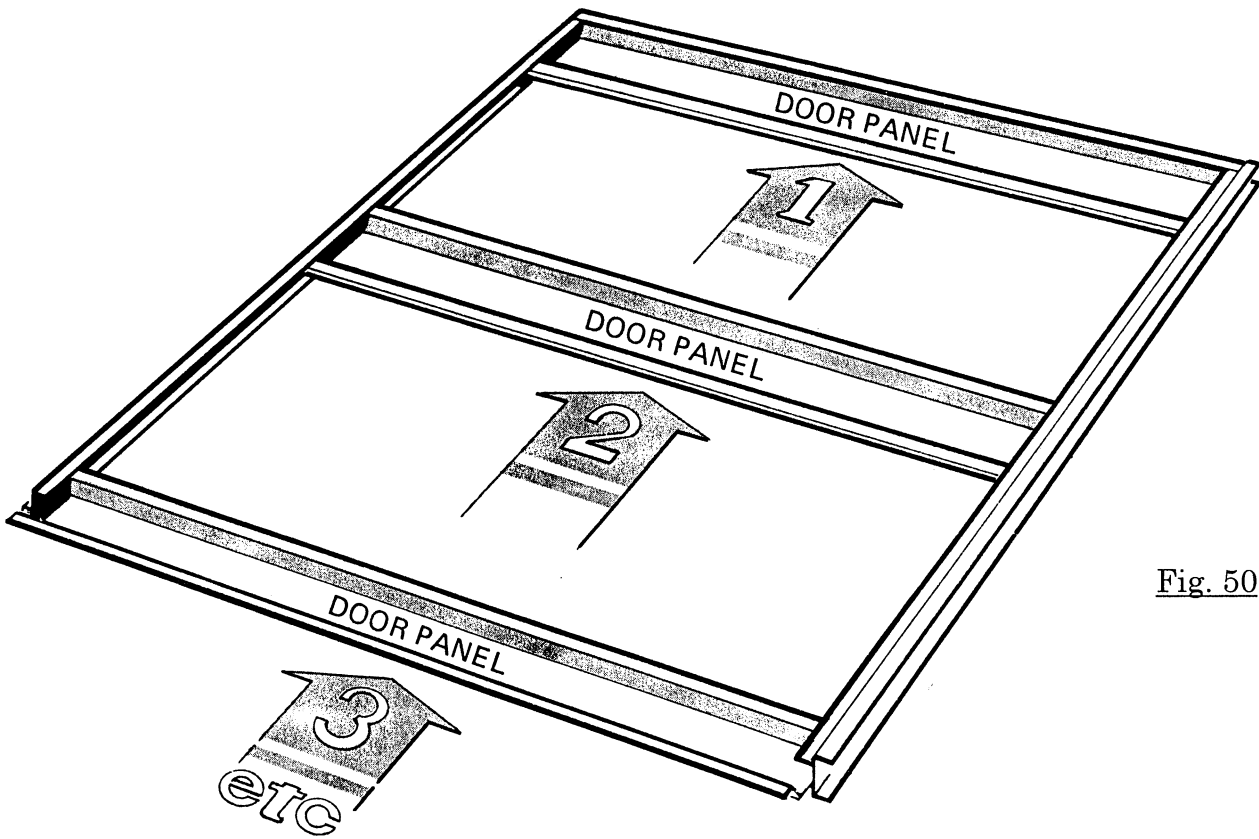

Fig. 50

It is very important to make certain that the door panels overlap each other properly: the higher panel must overlap the panel immediately below it, on the outside of the door. If this is not done, rain will seep into the seam and create corrosion. By proper lapping, water is prevented from leaking in (see fig.51).

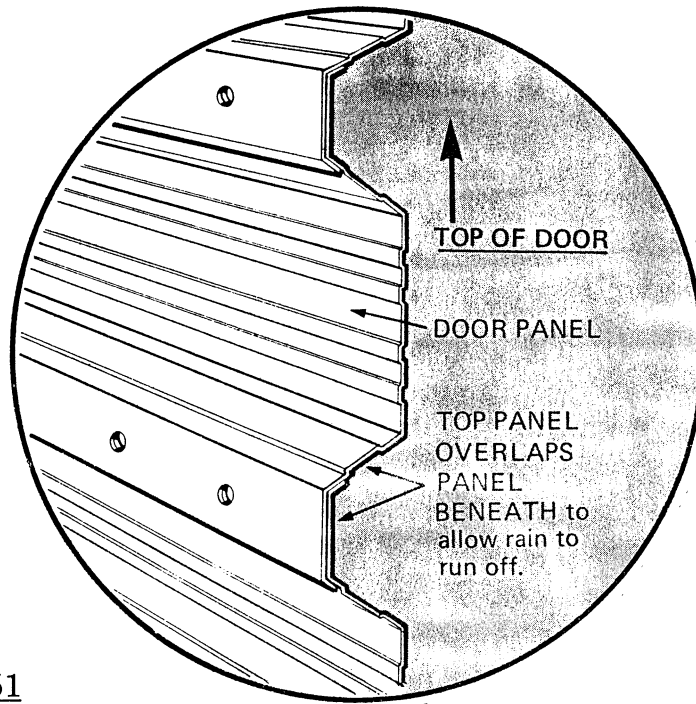

Fig. 51

The door may now be completed by bolting the bottom door channel in place after the last door panel has been inserted. First, however, make sure to bolt the bottom door guide securely to the bottom door channel (see fig.52), then bolt the bottom door channel loosely to the frame.

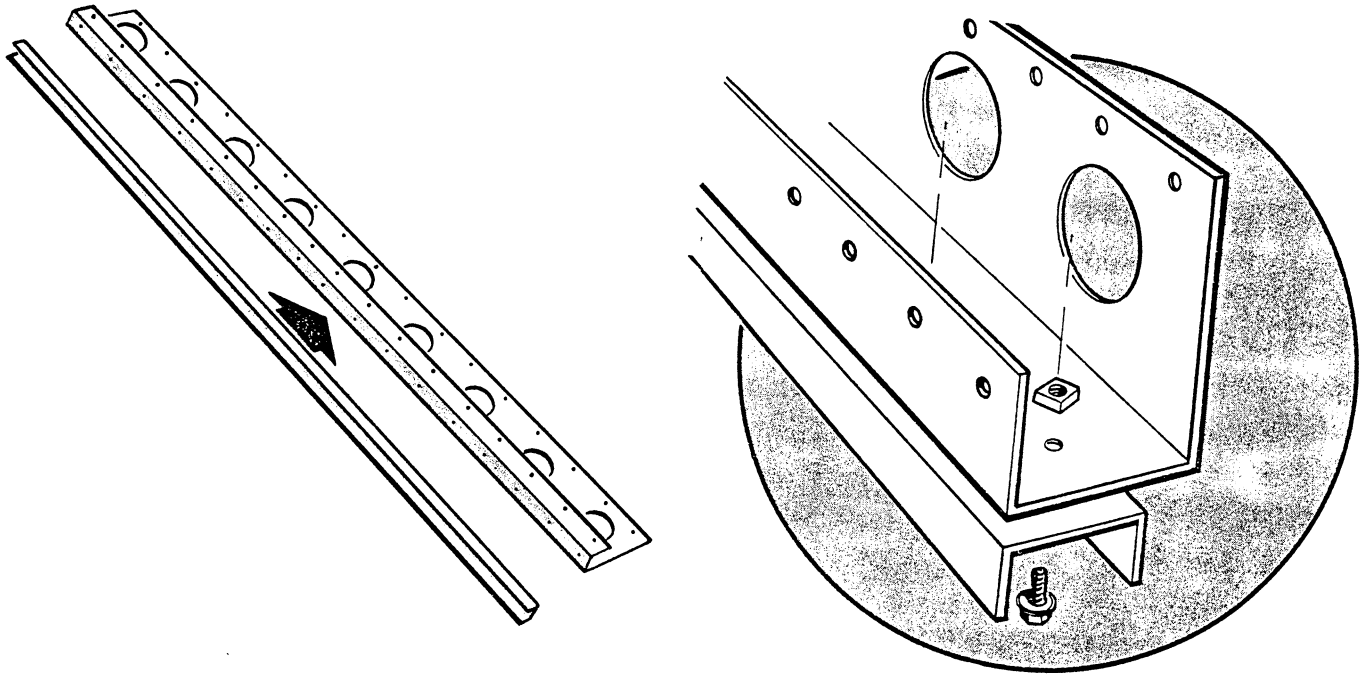

Fig. 52

If the door frame is reasonably square it should be easy to insert all bolts into the door panel holes. This is done by having a man insert the bolts from the top (this should be the outside of the door) and by having someone else put on the nuts underneath. The nuts should not be tightened until the door is perfectly square. The recommended procedure for squaring up the door is to leave it on the horses, and to measure diagonally, corner to corner. When the two diagonal dimensions are the same the door is square, and the bolts in the corners of the frame should be securely tightened, taking care not to disturb the squareness of the door. When the frame has been secured, all other bolts should be tightened. When this has been done the door should be lifted carefully and turned over. It is necessary to drill boltholes through the top and bottom door panels, so that they can be bolted to the top and bottom door channels. This can be done through the large round access holes in the channels.

NOTE: The bolts should be inserted from the outside of the door assembly, so that the nuts are inside the door, otherwise these bolts will cause interference with the door jamb.

When the door is ready for installation it should be lifted up by a number of men (2 to 6, depending on door size) and carefully placed in an upright position at the end of the header beam.

**CAUTION:** The larger doors catch the wind and may easily be distorted or blown over. Do not attempt installation on windy days.

The vertical post, which was temporarily installed, must be removed to install the door. The door is then lined up with the door track, and while one man guides the rollers into the track the others engage the door with the bottom door guide and slide it into the track. This process is repeated for the other door (see fig.53).

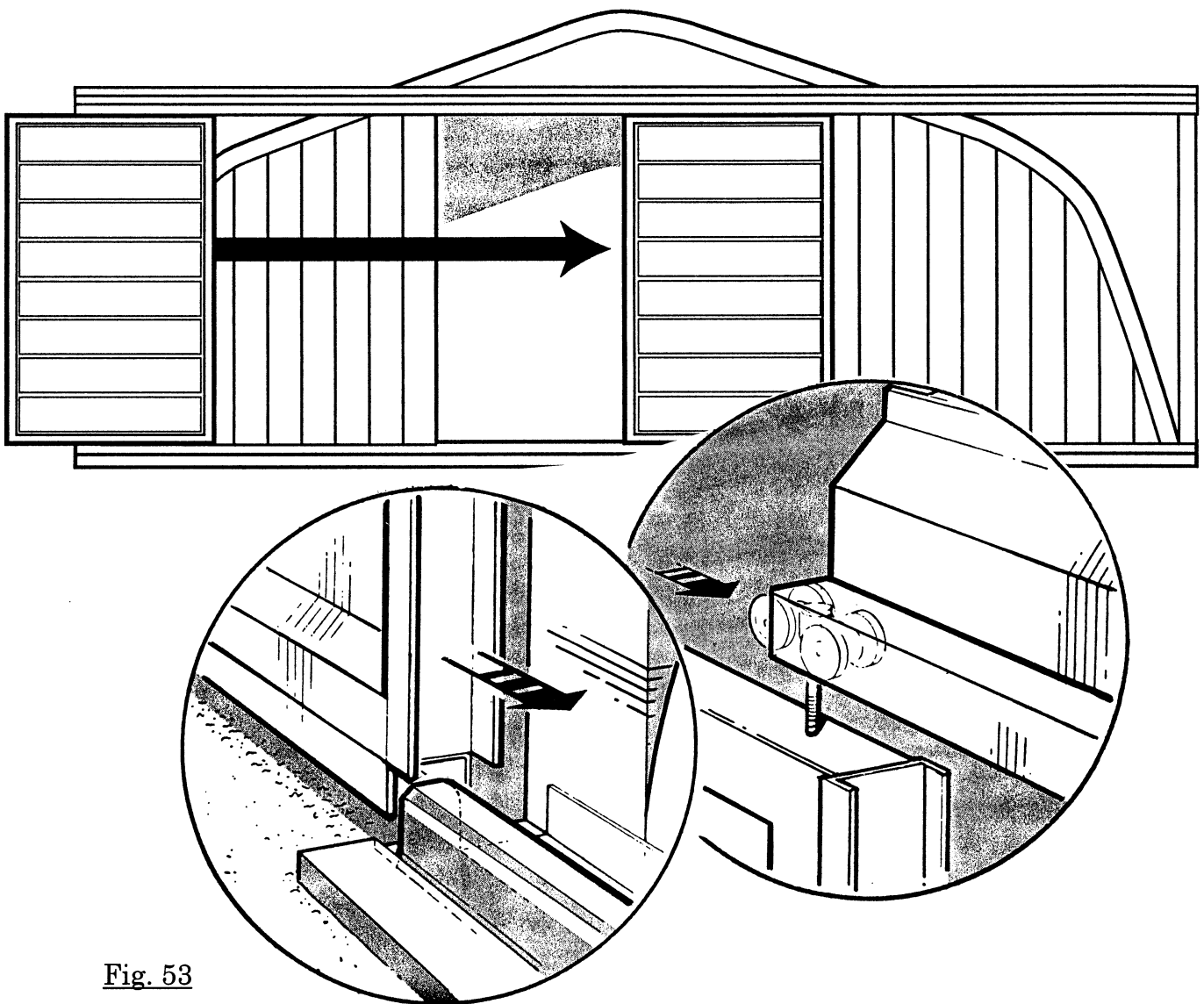

Fig. 53

The doors should be adjusted and leveled as required. Check both doors with a spirit level, and check whether they are running smoothly on the bottom door guides. If the two doors are brought together so that the one enters the center door seal of the other, the doors should be in perfect alignment. Any adjustments can be made by means of the door rollers. The threaded spindle in the center of the door rollers can be turned by means of needle-nose pliers or other suitable tools, adjusting either end of the door up or down (see fig.54). When all adjustments have been made, the locknuts on the spindles should be securely tightened.

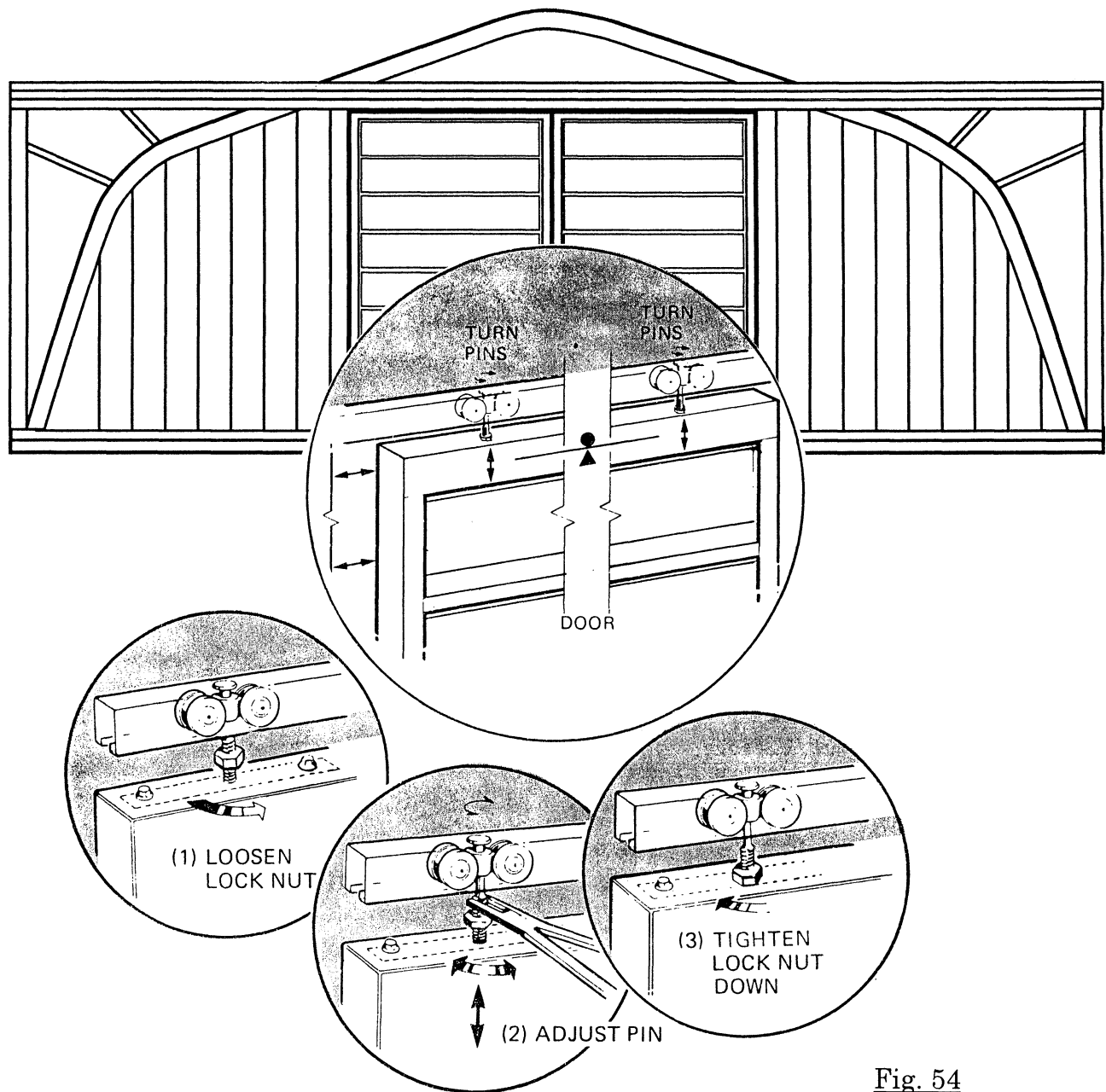

Fig. 54

The doors are completed by attaching the door handles and the door latch, which are all packed in the hardware box. The door latch is a toggle-type latch engaging a hook on the other door; it is easily installed by closing the doors and holding the latch and the hook in the right position, on the outside of the building. The boltholes are then marked on the door panels and drilled, after which the latch can be bolted on (see fig.55). The door handles are short pieces of pipe with flattened ends. Simply undo two doorpanel bolts on each door, vertically above each other, and bolt the handles on at a convenient height.

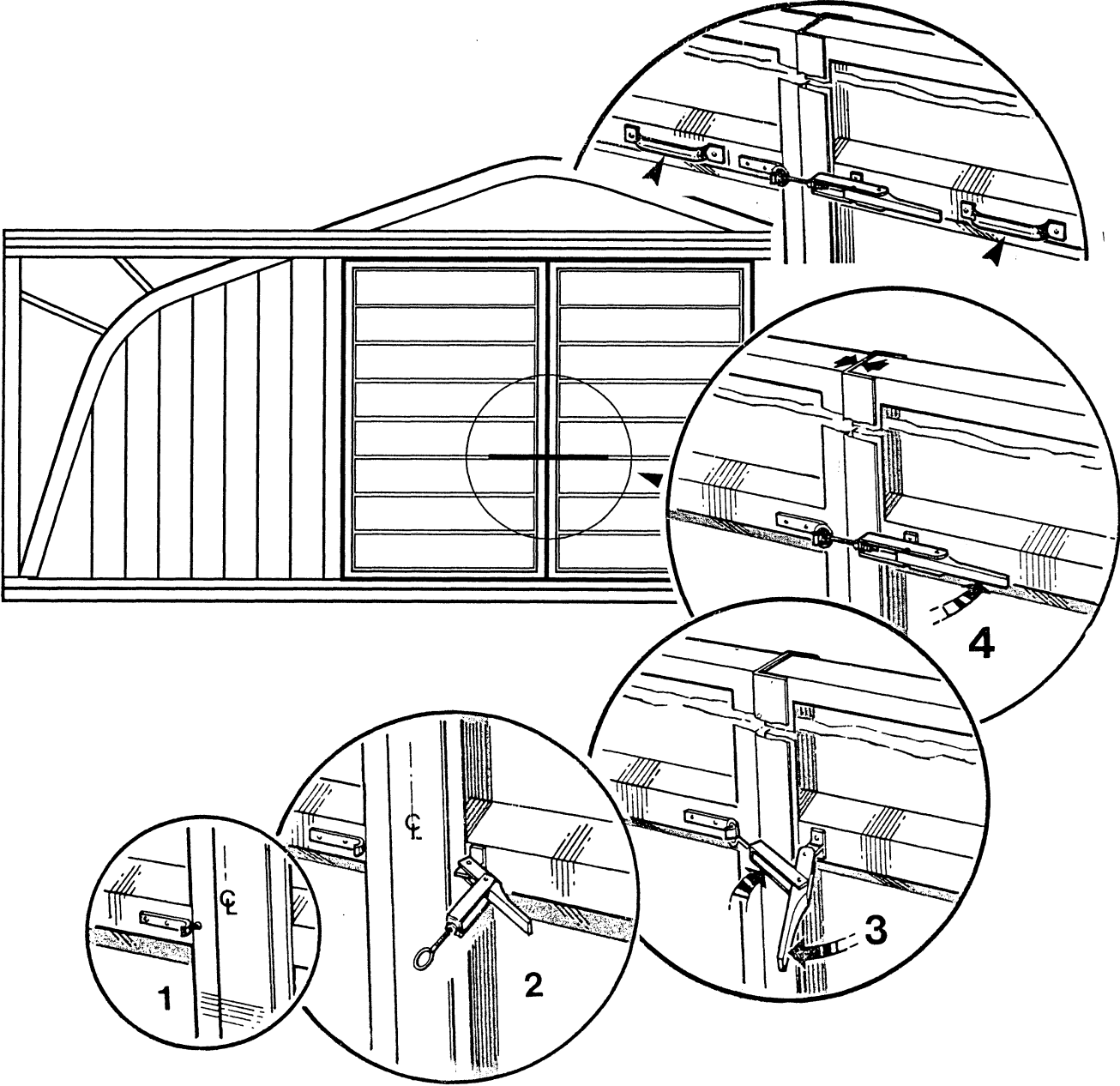
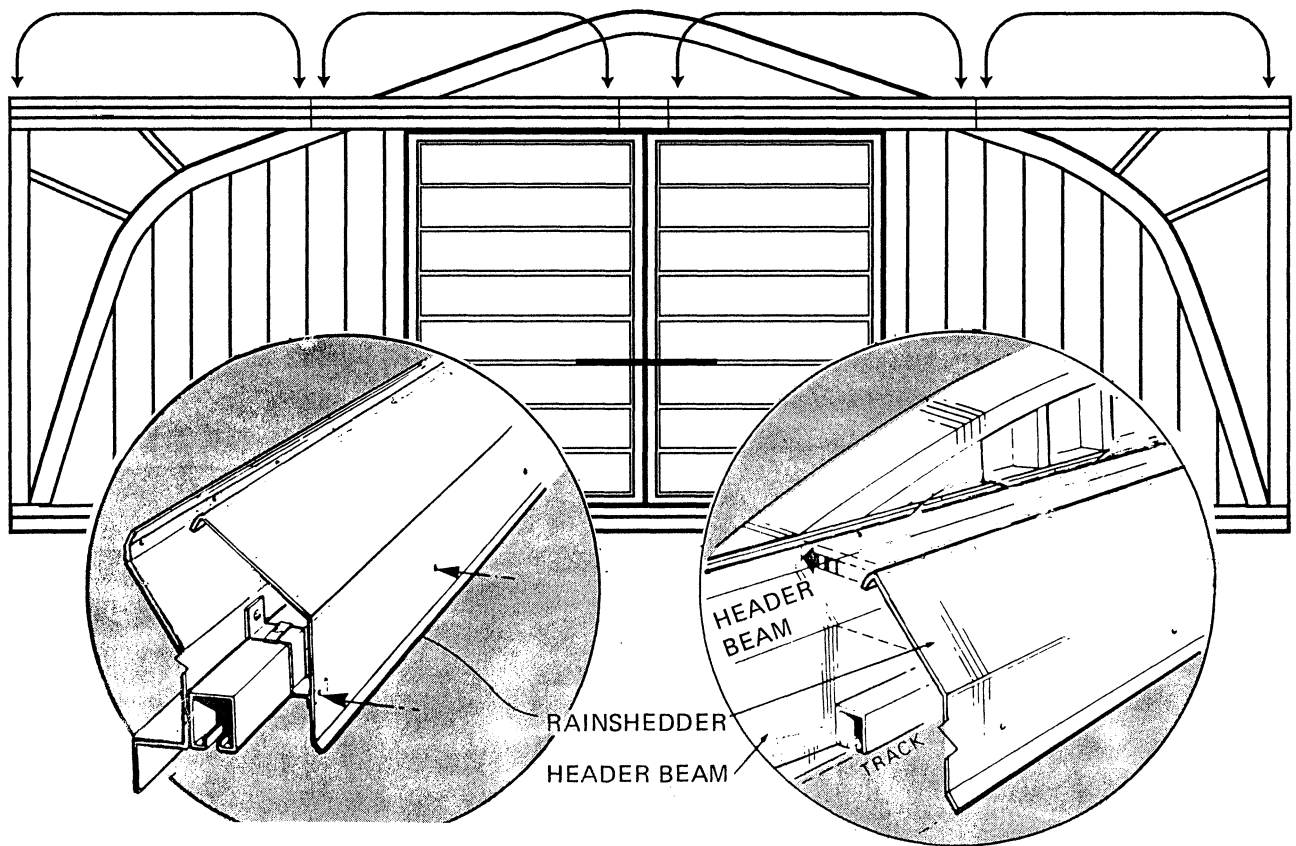

Fig. 55

When the doors have been installed and adjusted, the orange-colored rainshedder panels can be installed. The rainshedders are supplied in lengths of 12, 8 and 4 feet; check your packing list. You would have enough orange material to cover the entire length of the header beam, with the rainshedder panels overlapping each other by a few inches. The top of the panels is shaped like a hook; this hooks over the top flange of the header beam. The rainshedder panels are then secured to the track brackets using the self-drilling screws provided in the hardware box. A drill-screw should be used on each overlap as well, and it is recommended to attach the panels to the upper header beam flange with self-drilling screws at approximately two-foot centers.



**Fig. 56**

## SOLID ENDWALL

The erection of the solid endwall is relatively simple. Before the panels are installed, strips of foam stuffer must be inserted into the curved angles, exactly as was done at the other end. These stuffers provide a seal between the arches and the endwall panels. The center line of the building should be marked on the concrete. From this mark, measure a distance of 52 inches to either side, and mark this on the concrete as well. The endwall panels are shipped nested together. The six largest panels are set aside for the moment, and the other panels are installed in sequence towards the outside of the arch. Assembly of the solid endwall is started with panels 4B, the fourth panel left and right. Find these panels in the endwall bundle, ' measure the length of the longest side and compare this to the dimensions in your packing list to make certain you have the right panels. These panels are then placed in position with their inside edges on the 52" marks (see fig.57). Use a few bolts to keep the panels in place, but do not tighten the bolts until the endwall has been checked dimensionally.

NOTE: The endwall panels can not be made longer than 16 feet. If your ALPINE building is higher than 16 feet, some of the panels must be put together by joining a short piece (the upper panel) to a straight 16 ft. piece (the lower panel). This is done by overlapping the two panels 12 inches. The lap should be on the outside, so that rain cannot run down into the seam. When all tall panels have been spliced like this they are installed just like the shorter panels.

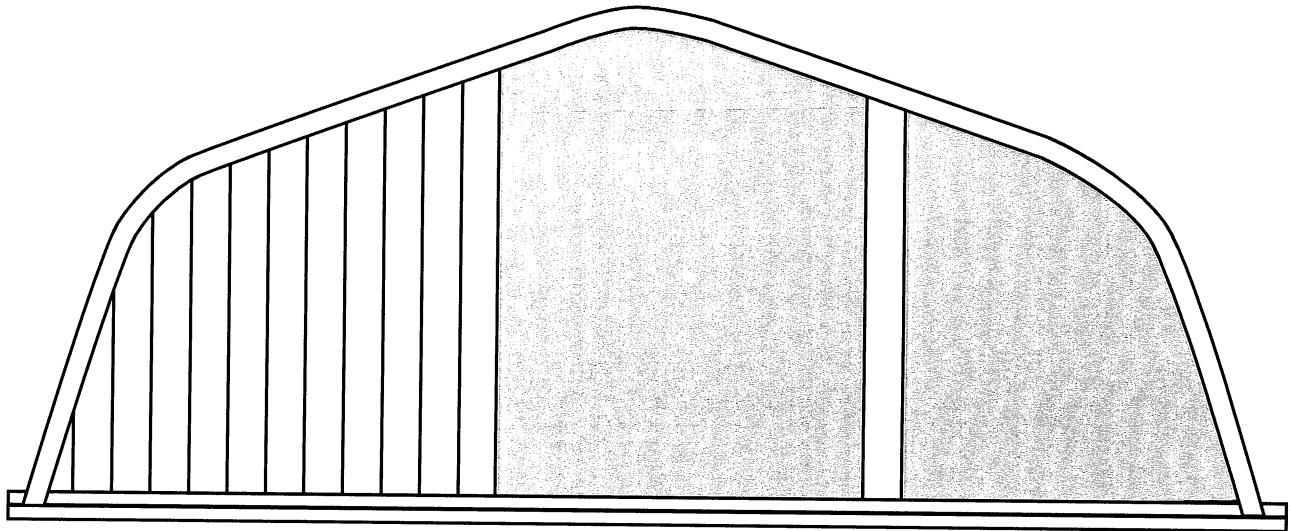

Fig. 57

To help maintain the proper spacing of the panels prepunched strapping angles are provided, which have been used previously to space the arches. They are temporarily bolted onto the endwall to space the panels correctly. The big opening in the center of the endwall should now be checked at the top and at the bottom. It should be exactly 8'-8" wide, edge to edge, and the edges of the panels should be plumb. It is good practice to measure the opening diagonally as well. The endwall panels should be adjusted until the opening is plumb and square, and then they can be secured by drilling holes through the panels and the inner and outer curved angles, as was done at the doorwall. When all panels have been bolted up, the six remaining panels are used to fill in the opening in the center. The six panels must be drilled and bolted to the curved angles as well. Once this is done, all bolts for the entire endwall can be inserted and tightened. The flat corner panels are installed last; this is done exactly as described earlier, on page 49.

The building is now completely assembled, and all bolts should be tightened before the final grouting is done. Carefully check all arches and both endwalls, insert all missing bolts and make sure that all bolts are properly tightened. The best way to do this is with an impact gun, but the gun must be adjusted so that the bolts are not over-tightened.



## GROUTING

When the assembly of the steel has been completed the building must be anchored to the foundation by filling the foundation troughs with cement grout. The round shape of the arches may result in wind suction during strong gusts of wind, which might lift some of the arches out of the troughs. It is therefore important to grout the building as soon as the assembly is completed. Grouting also contributes to the stiffness of the arches, resulting in a stronger building.

**CAUTION:** Grout must not contain any corrosive substances, such as calcium chloride, as this may result in corrosion of the steel. Ask your concrete supplier!

**NOTE:** The steel panels are protected by a coat of special oil. This oil may affect the bond between the steel and the concrete, and we suggest that the panels be cleaned by wiping with varsol or other suitable solvents. As Galvalume steel is sensitive to the chemical reaction of concrete during the curing period, it is recommended to spray the ends of the panels with a thin coat of lacquer or varnish before grouting.

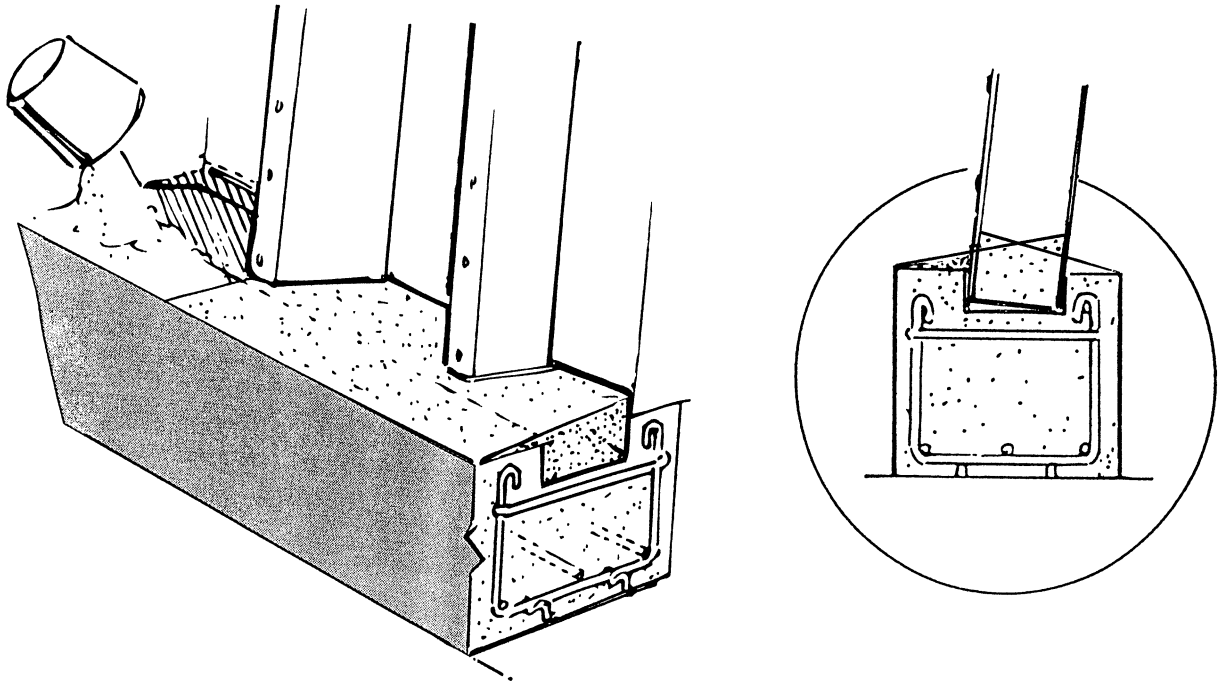

Fig. 58

The arches must be grouted both inside and outside the building. The troughs should be filled a little higher than to the top of the foundation, so that the grout can be finished to slope down, away from the steel, at an angle of about 20 degrees. This helps prevent having standing water in contact with the steel. See fig.58.

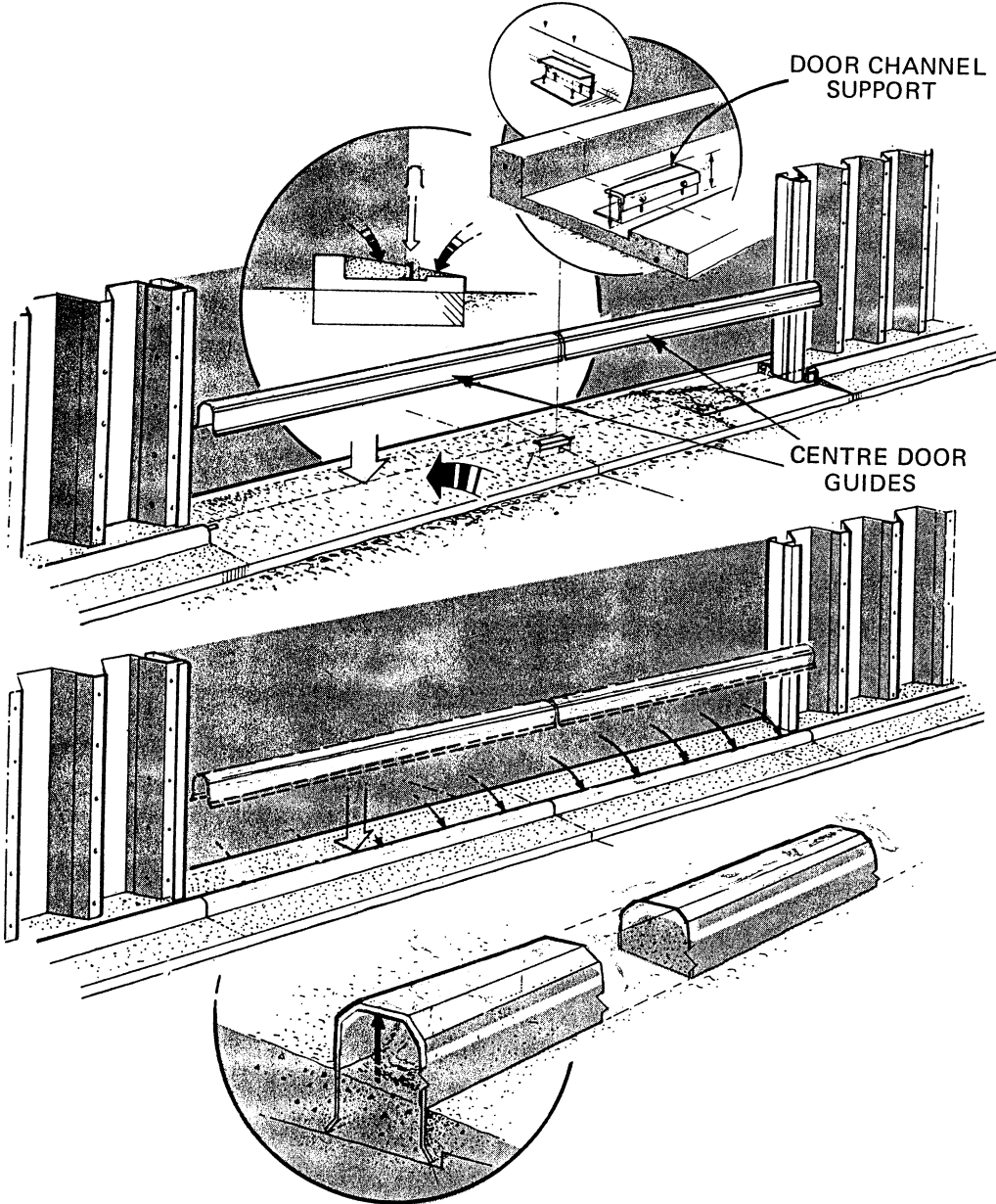

Fig. 59

Cement grout should be thin enough to work it evenly and completely into the troughs; no voids should be left. Grout should never be watered down too much, however: too much water seriously reduces the strength of the mix. The solid endwalls are grouted in the same fashion as the arches, and finished with a similar 20 degrees slope. Grouting also contributes to the stiffness of the endwalls; as mentioned before, it should be done as soon as possible to avoid wind damage. Grouting the doorwall requires special attention, as the door guides are installed at the same time. You will find two 6-inch long brackets in the hardware box for each doorwall. These brackets are bolted together; the bolt holes are slotted so that the brackets can be adjusted up or down. The assembled brackets are installed in the center of the door opening, to support the inner door guides. The inner door guides can now be put in place, suspended on the small tabs of the outer door guides and on the center brackets. The brackets must be adjusted until the entire line of door guides is perfectly straight and level, so that the doors will slide without binding. When this adjustment has been completed the center brackets can be bolted to the foundation using small lag screws; this step is not absolutely necessary, but it is recommended to reduce the danger of moving the brackets while the grout is being poured. The inner door guides are turned upside down and filled with grout. A solid fill is recommended to avoid crushing the door guides, by the weight of vehicles with solid tires for instance. The trough is then filled with grout to the level shown in fig.59, and the grout-filled door guides are placed back in position, and pushed firmly down into the grout.

NOTE: It is often more practical to fill the inner door guides with concrete when the foundation is being poured. In that way, they will be solid when the grouting is done later on.

Before the grout sets, make sure to check the alignment of the door guides carefully. When all door guides are level and properly in line the grouting in the doorwall trough may be finished by troweling, with a slight slope away from the building. The tops of the inner door guides should project 1 inch to 1 1/2 inches from the grout (see fig.59).

## INSTALLING VENTILATORS

Locate the ventilator boxes in your shipment; the vent adapter is usually packaged in a separate carton.

**CAUTION:** We recommend a minimum spacing of 20 feet or 10 arches between ventilators. Ventilators should only be installed at the peak of your ALPINE building.

Take the vent adapter and place it in the right location. With a felt-tip marker, trace the inside of the opening onto the arches (see fig.60).

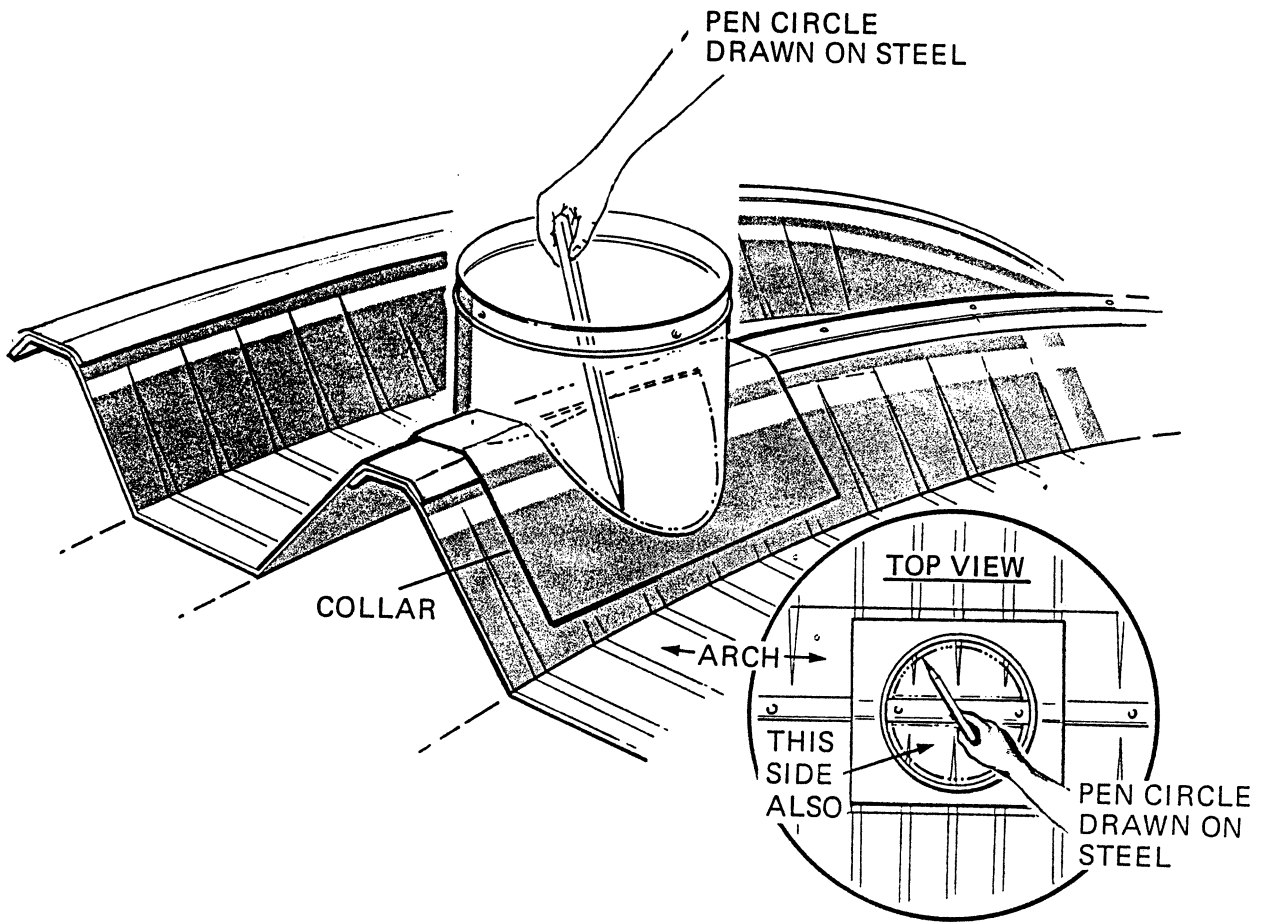

Fig. 60

Drill a hole to have a starting point; then, with a keyhole-type hacksaw, cut two semi-circular openings in the arches. We recommend leaving the bolted strip in the middle of the hole intact (see fig.61).

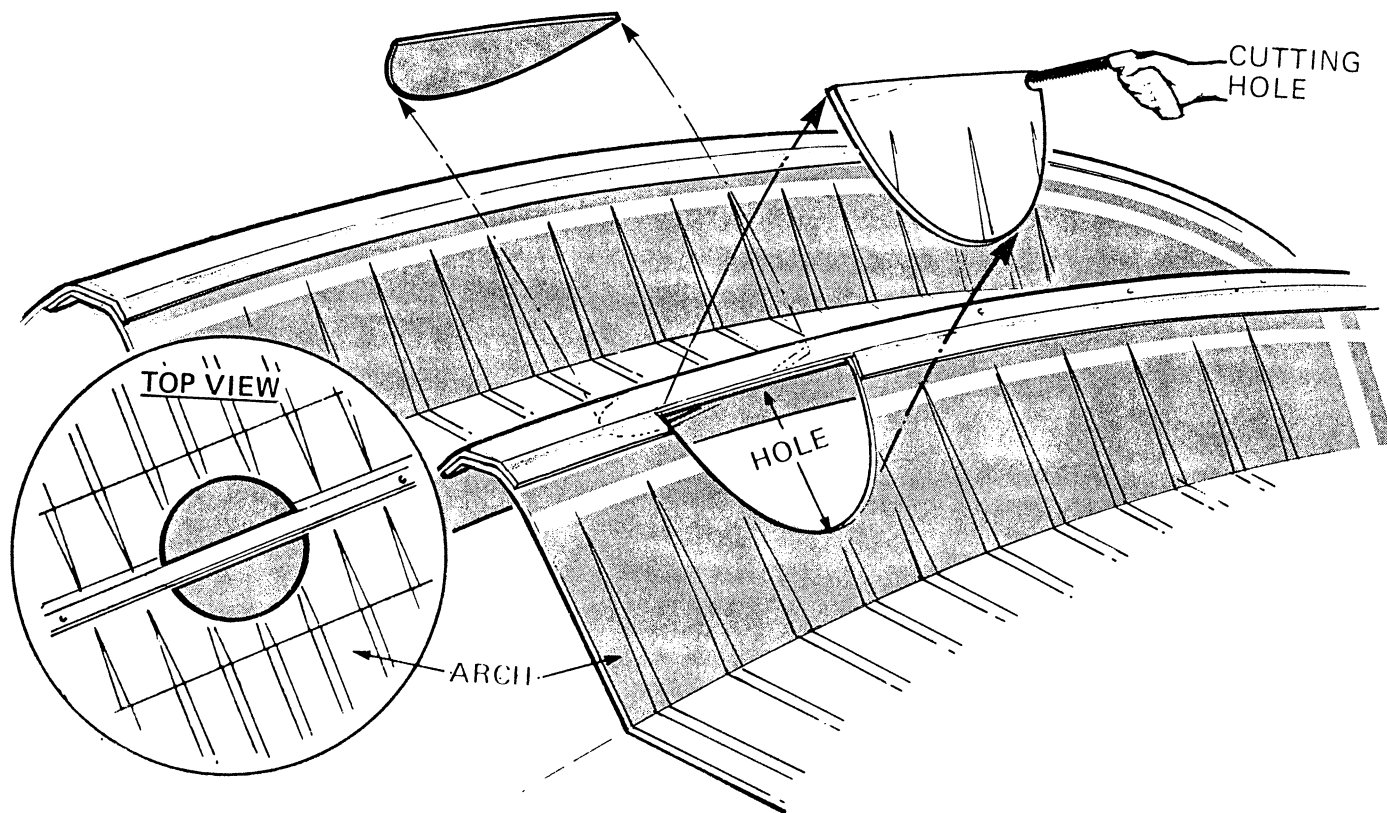

Fig. 61

Put a bead or a strip of caulking, if used, all the way around the holes for sealing. Now, place the adapter back in position and press it firmly down until it is properly seated on the arch profile. Then, drill a number of holes through the flat flanges of the adapter and the arches underneath it, and bolt the adapter firmly to the arches (see fig.62).

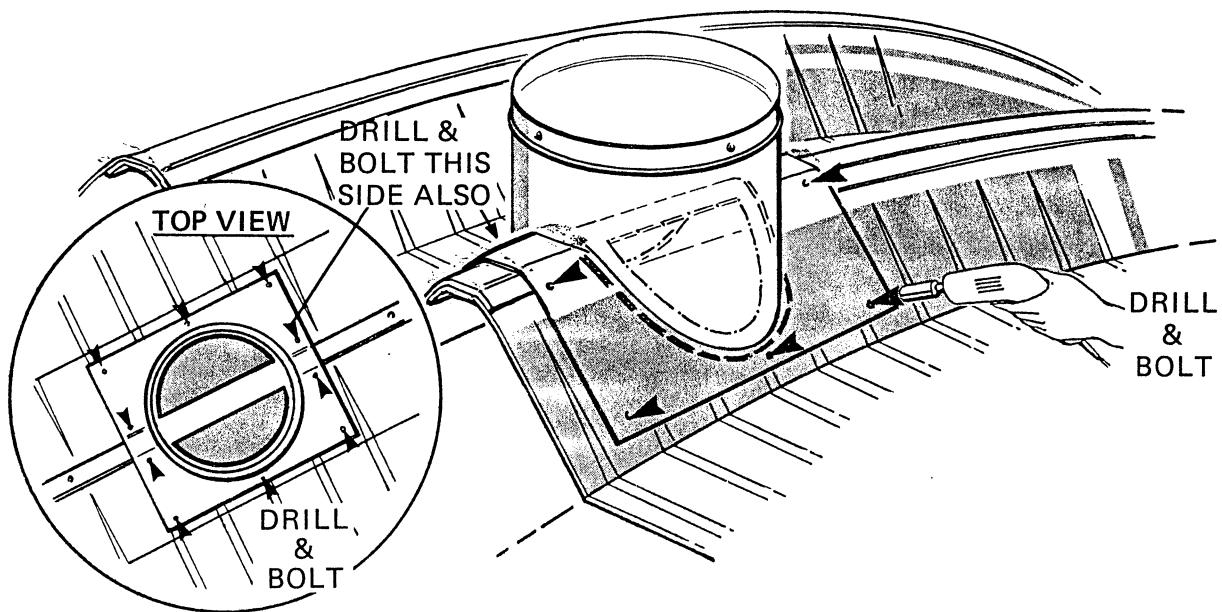

Fig. 62

Carefully install the turbo-ventilator or the stationary ventilator on top of the adapter, drill a few holes through the ventilator collar and the adapter and insert bolts to secure the ventilator. See fig.63.

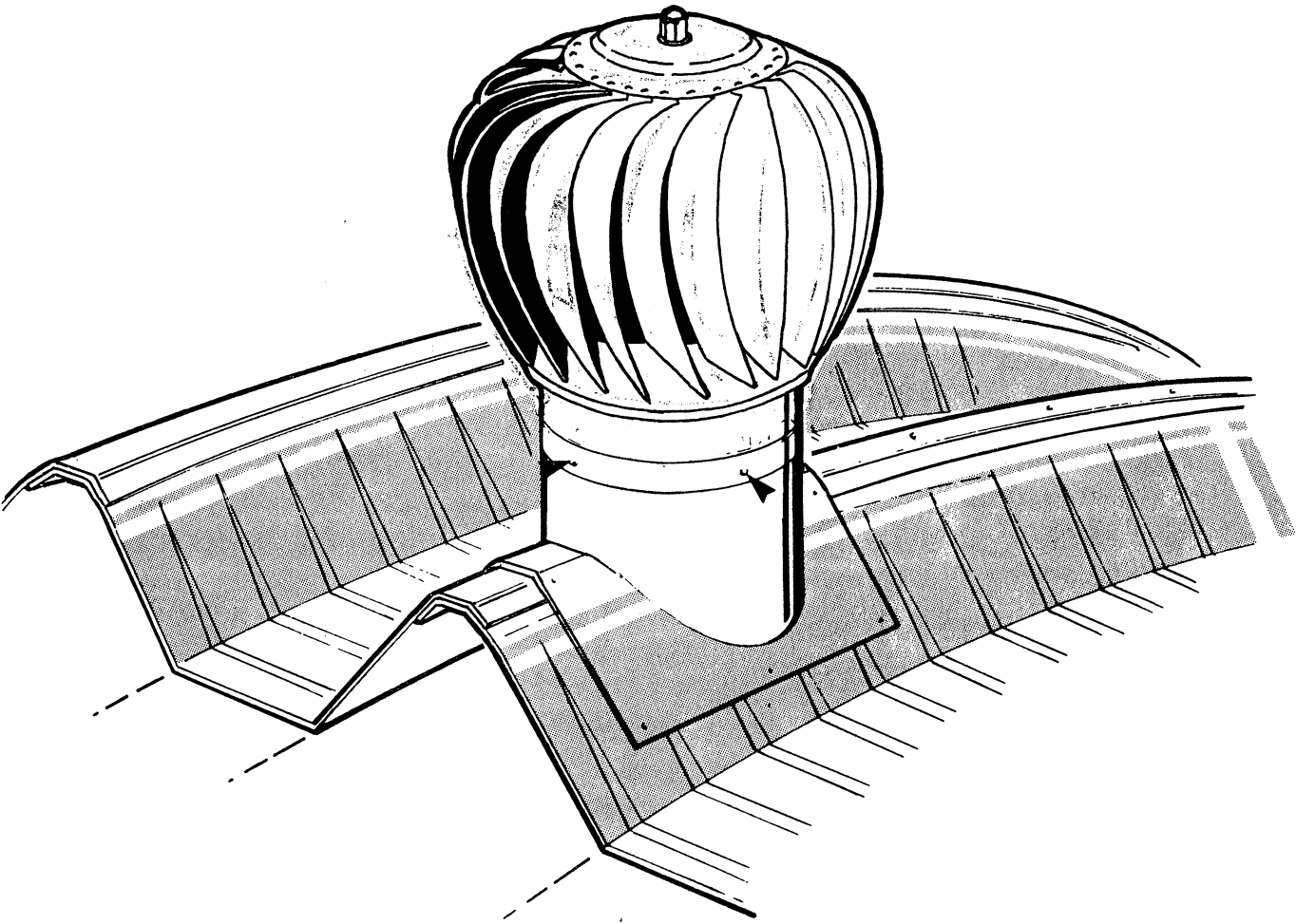

Fig. 63

## INSTALLING SKYLIGHTS

We suggest installing skylights at the peak of the building or close to it. Remove all bolts from the steel panel you want to replace by a skylight, and lift out the panel (see fig.64).

**CAUTION:** We recommend restricting the number of skylights used to one skylight per every ten arches. Skylights are not as strong as steel panels, and especially where heavy snowfall is involved, using too many skylights could seriously endanger structural integrity. You should never attempt to erect an arch containing a skylight; put up the arch with steel panels only, and replace a steel panel later on. Skylights usually break if they are installed in an arch before the erection.

**NOTE:** If the arches are made of heavier steel than the standard arch thickness, extra heavy skylights are available. Ask your dealer for prices and details.

**NOTE:** The number of steel panels shipped is automatically reduced by the number of skylights ordered. If, for example, you order two skylights, then the factory will ship two steel panels less than a full set.

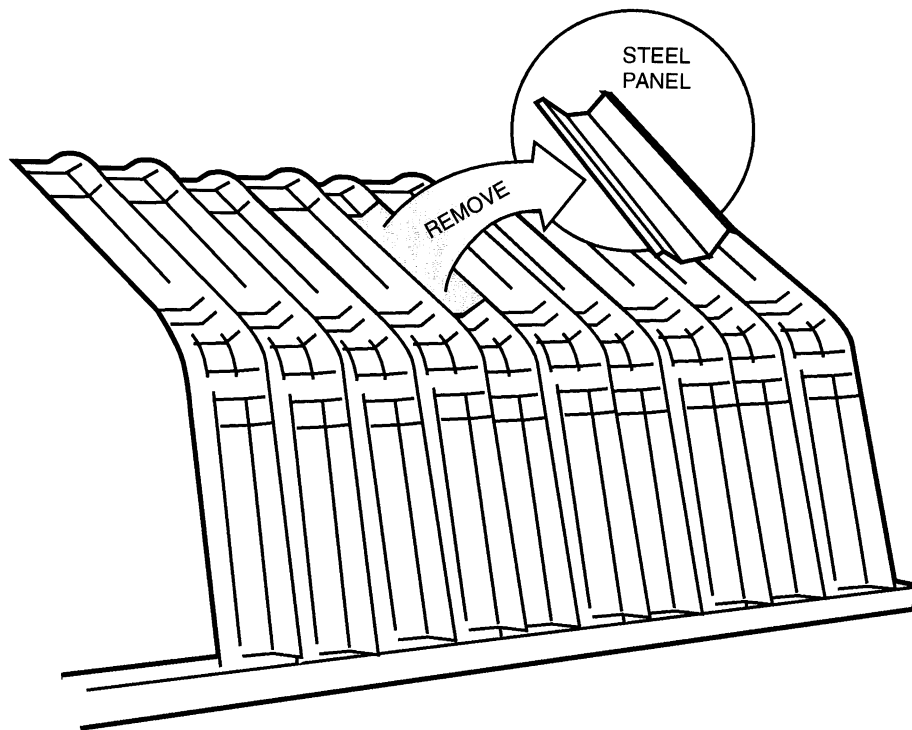

Fig. 64



The skylight is carefully placed into the opening, overlapping the panel below it, just like the steel panel did. When the skylight has been positioned it should be secured by supporting it from within the building, while someone outside the building marks the boltholes with a felt-tip marker (see fig.65).

The skylight is then removed for drilling the marked holes. When all holes have been drilled, caulking (if used) is applied along all edges and the skylight is put back in place and bolted up.

**CAUTION:** Fiberglass can be brittle, especially at lower temperatures. Avoid bending or twisting the skylights, and drill the holes slowly and carefully, or else you may crack the skylight, causing leakage.

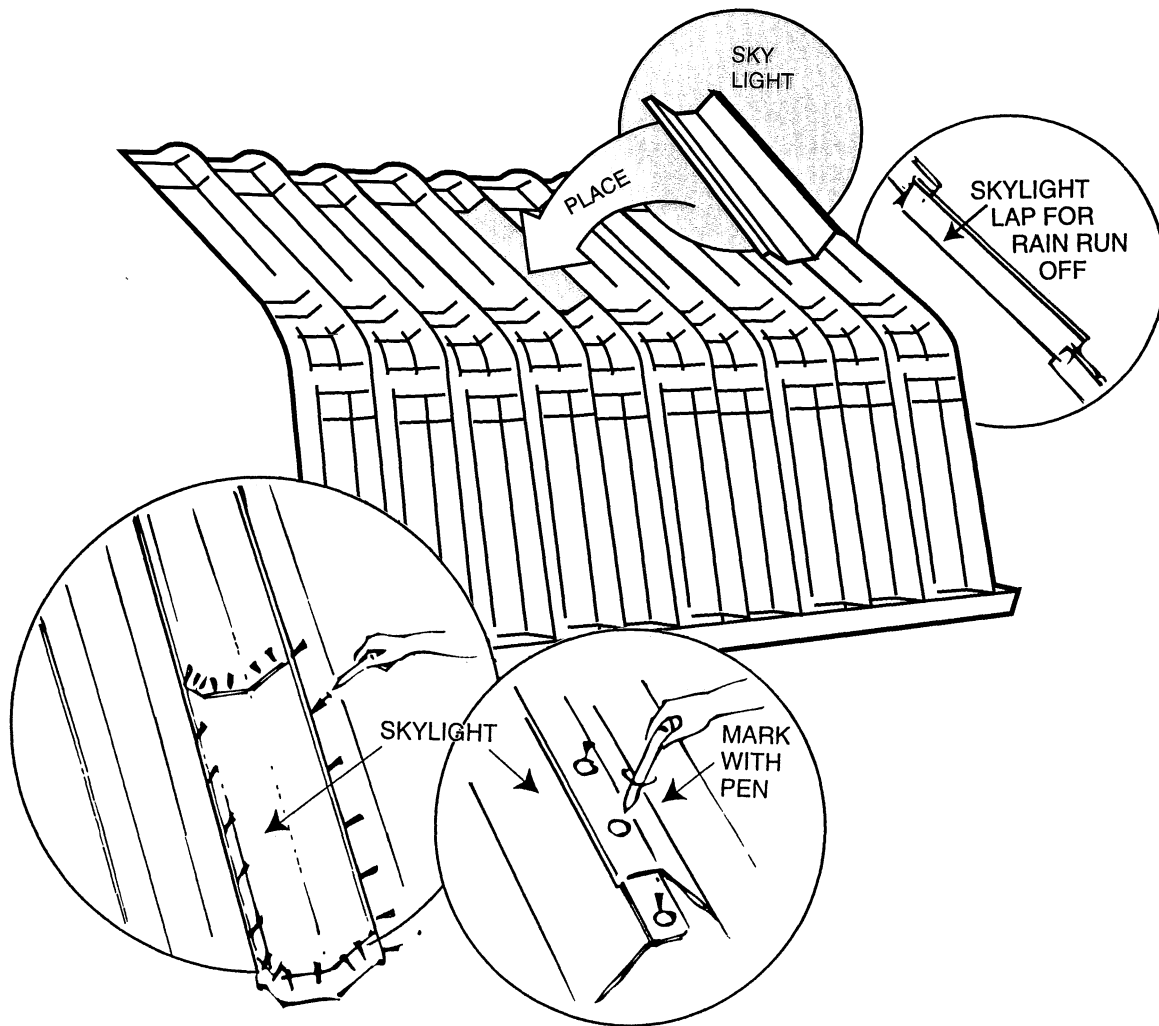

Fig. 65

## INSTALLING SERVICE DOORS

Service doors can easily be installed in the endwalls. They are shipped completely assembled and hung in a steel frame, ready for installation in the endwall.

NOTE: Service doors are usually shipped on top of the load, and are offloaded first. Check for visible damage, and if the door has been damaged, bring it to the driver's attention.

NOTE: Service doors must be installed in the endwalls BEFORE the endwalls are grouted in.

NOTE: If the service door is intended for installation in a doorwall, beside the main door, remember to leave at least one endwall panel between the main door and the service door.

When you are deciding where to put the service door, take into account that you have to remove three adjoining panels, all of which must be a minimum of 8 feet long, otherwise the door will not fit into the opening (see fig.66).

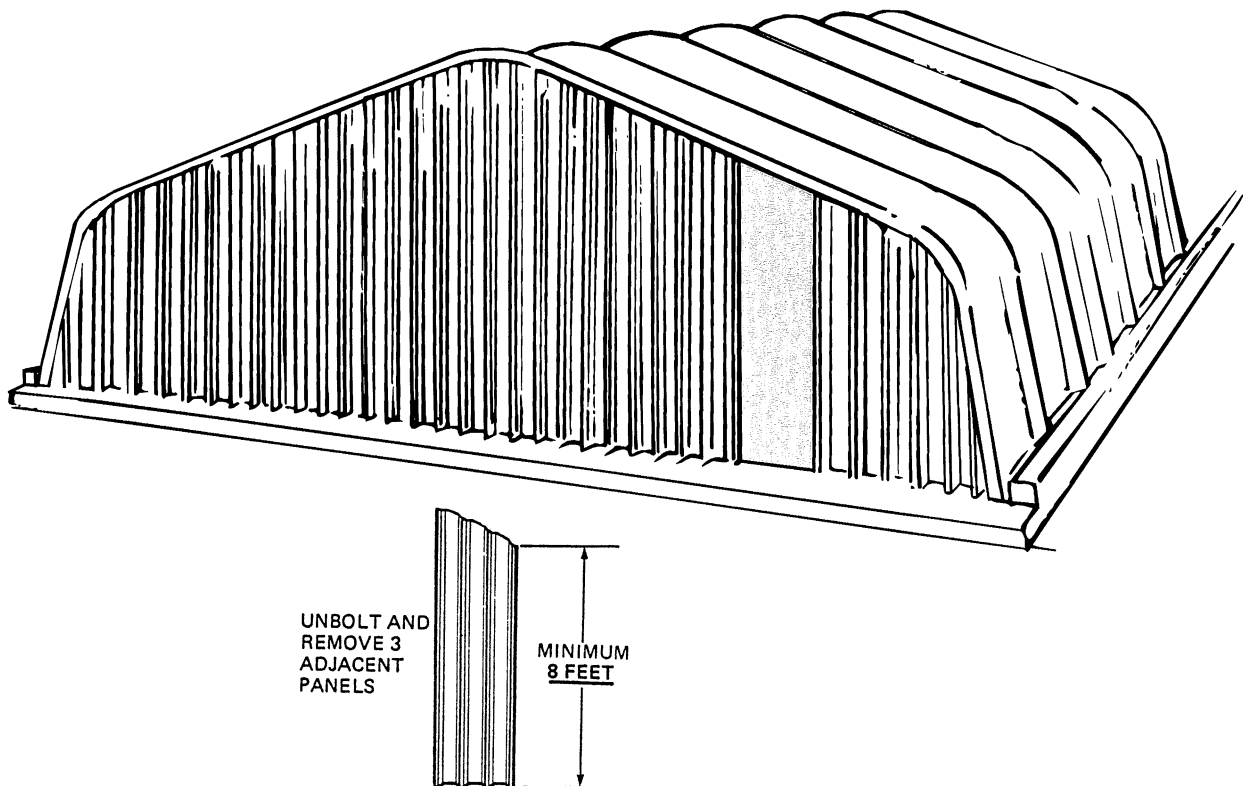
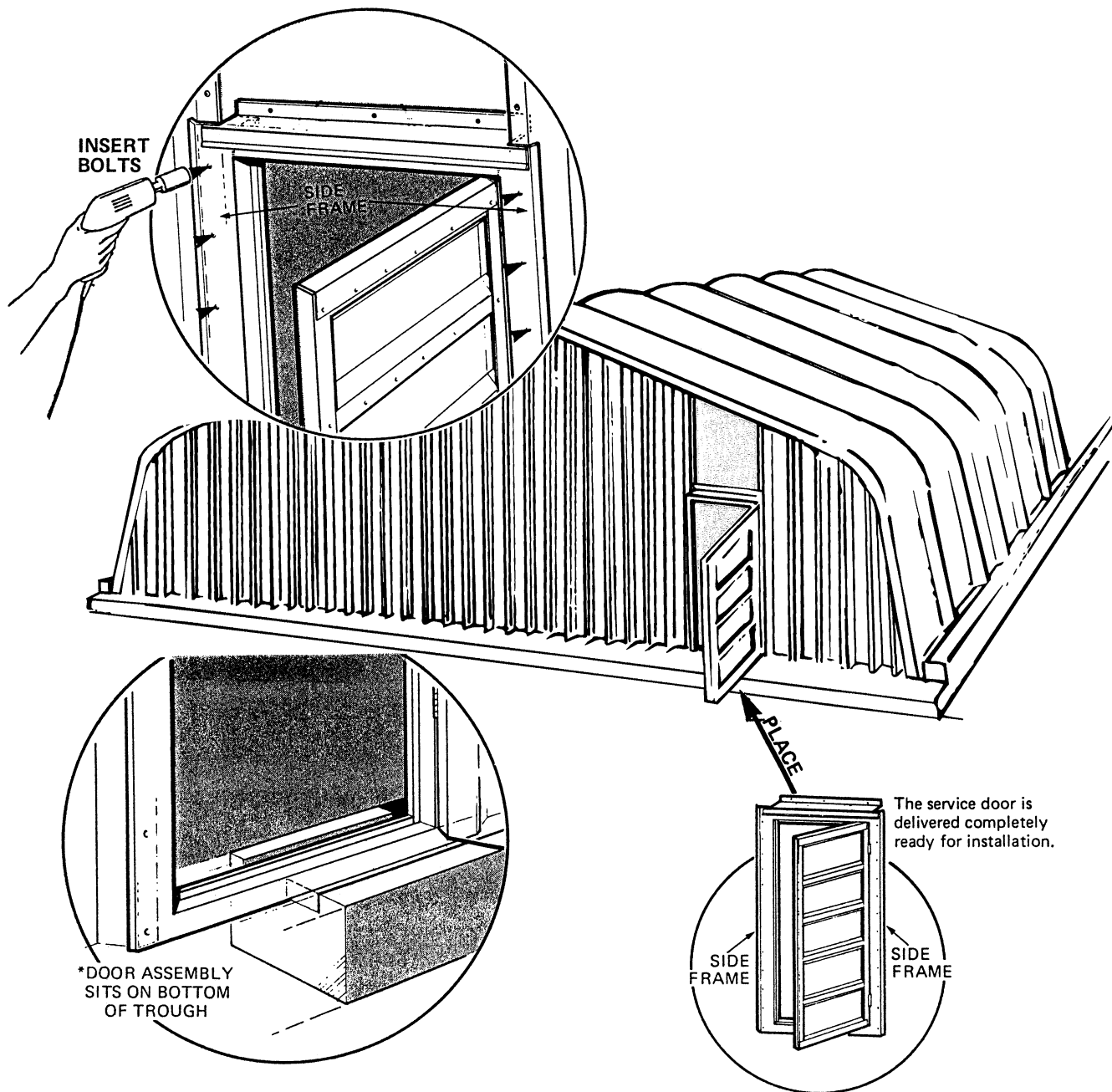

Fig. 66

When you have decided on the best location for the door, unbolt and remove the three endwall panels, and simply lift the complete service door assembly into the opening. Line up the boltholes in the door frame with the holes in the endwall panels next to the door, insert the bolts and tighten them (see fig.67). The service door assembly is designed to be positioned in a 4-inch deep endwall trough, and is grouted right into the trough when the whole endwall is grouted.



**Fig. 67**

Now go back to the three endwall panels which were removed to make an opening for the door, and cut exactly 7'-10" off the bottom of all three panels. Then put the tops of the panels back over the service door, and bolt them to the adjacent panels and to the curved angles again (see fig.68). From inside the building, drill through the holes in the top of the door frame, insert bolts and tighten them. This completes the installation of the door.

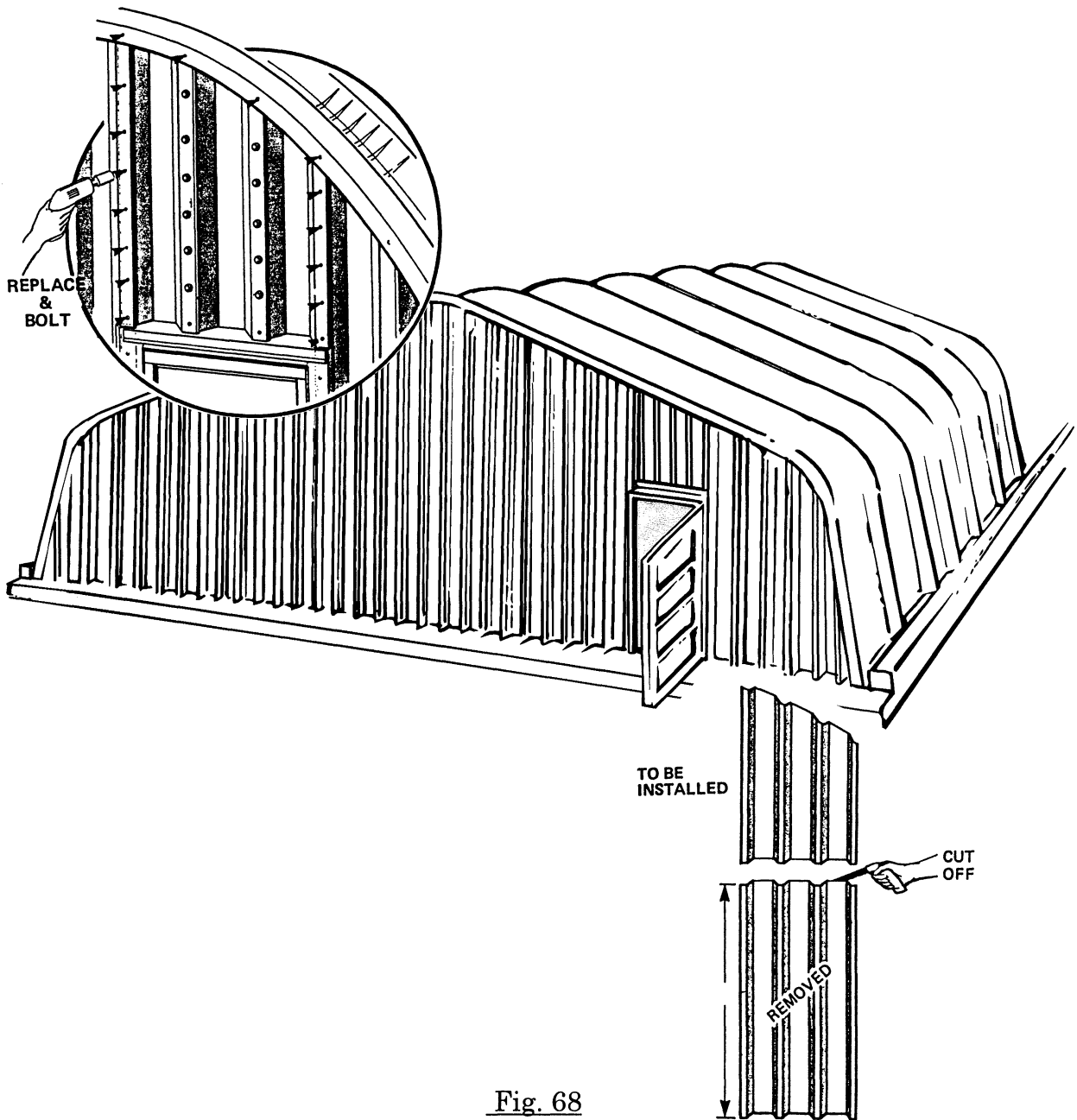

Fig. 68